

***Valedictorian® - Vertical Unit Ventilator
Models VFF and VFV***



Introduction

Modine Manufacturing Company, located in Racine, Wisconsin, is one of the world's leading manufacturers of heat pump and air conditioning systems for schools. Our reputation for product excellence has been earned through innovative design and high quality manufacturing. The highest quality controls and component parts are engineered into all of our products.

State-of-the-art test facilities in the UK, USA, and Germany reflect Modine's commitment to the latest design and manufacturing technology to maintain leadership in the production of systems of unsurpassed quality and reliability.

Our Valedictorian® product has been designed to be tough, dependable, aesthetically pleasing, quiet, and easy to install. The unit is built with heavy-duty construction and incorporates a draw-through design with a variety of heating, cooling and ventilation configurations. Discharge temperature is controlled using either a face-and-bypass damper or a modulating control valve. In addition, available adapter backs in common sizes allow you to easily upgrade existing systems. Optional factory installed controls and piping packages have been engineered to ease installation.

Modine's unique design and wide range of systems and options help create a healthier and safer learning environment for our children.

Table of Contents	Page
Model Nomenclature	3
General Description	
Standard Features.....	4-5
Options - Factory Installed.....	6-7
Accessories - Field Installed.....	8-9
Component Location.....	9
Valve Control Units.....	10
Face & Bypass Units.....	10
Dimensional Data	
Dimensional Data – 16 5/8" Units.....	11
Dimensional Data – 21 7/8" Units.....	12
Inlet Air Arrangements for 16 5/8" Units.....	13
Inlet Air Arrangements for 21 7/8" Units.....	14-15
Piping Connection Locations.....	16
Performance Tables	
Cooling Capacity.....	17
Heating Capacity.....	18
Sound Data.....	18
Technical Data	19
Chilled Water Cooling Capacity.....	19
Hot Water Heating Capacity.....	19
Electrical Data	19
Controls	
Field Installed Controls by Others.....	20
Factory Installed DDC Ready Controls.....	20
Factory Installed Carel Controls.....	20
Control Sequence.....	20-22
Accessories	
Side Panels.....	23
Utility Compartments.....	24
Filler Sections.....	24
Sub-Bases.....	25
Duct Flanges.....	25
Wall Sleeves and Louvers.....	26
Piping Components.....	27

Modine has a continuous product improvement program and therefore reserves the right to change design and specifications without notice.

Model Nomenclature

1	2	3	4-7	8	9	10	11	12	13	14	15	16	17
PT	S	CC	US	IA	DA	CO	HO	CA	CP	OA	SV	MT	EC

Digit 1 - Product Type (PT)

V - Valedictorian® Unit Ventilator

Digit 2 - Style (S)

F - Floor Mounted

Digit 3 - Cooling Control (CC)

V - Valve Control

F - Face and Bypass

Digits 4, 5, 6 & 7 - Unit Size (US)

750 - 750 cfm

1000 - 1000 cfm

1250 - 1250 cfm

1500 - 1500 cfm

Digit 8 - Inlet Air (IA)

A	16 5/8 Unit Depth	Rear Outside Air	Open Pipe Tunnel
B		Rear Outside Air	Closed Pipe Tunnel
C		Bottom Outside Air	Open Pipe Tunnel
D		No Outside Air	Open Pipe Tunnel
E	21 7/8 Unit Depth	Rear Outside Air	Open Pipe Tunnel
F		Rear Outside Air	Closed Pipe Tunnel
G		Top Window Intake	Closed Pipe Tunnel
H		Bottom Outside Air	Closed Pipe Tunnel
J		No Outside Air	Closed Pipe Tunnel
K		2" Step-Down	Open Pipe Tunnel
L		2" Step-Down	Closed Pipe Tunnel

Digit 9 - Discharge Air (DA)

A	Top Discharge	Bar Grill and Screen
C		Opening Only (field duct connection)

Digit 10 - Cooling Option (CO)

0 - None

2 - 2-Row Chilled Water/Hot Water 2-Pipe

3 - 3-Row Chilled Water/Hot Water 2-Pipe

4 - 4-Row Chilled Water/Hot Water 2-Pipe

Digit 11 - Heating Option (HO)

0 - None

1 - 1-Row Hot Water Coil

2 - 2-Row Hot Water Coil

Digit 12 - Coil Access (CA)

A - Right Hand Coil(s)

B - Left Hand Coil(s)

C - RH Cooling - LH Heating

D - LH Cooling - RH Heating

Digit 13 - Coil Positions (CP)

0 - Units with One Coil

1 - Preheat: Pos 1 Heating, Pos 2 Cooling Coil

2 - Reheat: Pos 1 Cooling, Pos 2 Heating Coil

Digit 14 - Outside Air Damper Assembly (OA)

A - Standard Damper

C - Insulated Damper

E - No Damper (Recirculating Unit)

Digit 15 - Supply Voltage (SV)

A - 115/60/1

B - 208/60/1

C - 230/60/1

Digit 16 - Motor Type (MT)

1 - Standard

2 - High Static - EC Motor

Digit 17 - Electrical Connections (EC)

A - Left Hand Side

B - Right Hand Side

Modine endeavors to ensure that the information contained in this document is correct and fairly stated, but none of the statements contained in this document are to be relied upon as a statement or representation of fact. Modine does not accept liability for any error or omission, or for any reliance placed on the information contained in this document.

The development of Modine products and services is continuous and therefore the information contained in this document may not be up to date. It is important to check the current position of Modine at the address shown at the end of this document. This document is not part of a contract or license save insofar as may be expressly agreed.

No part of this document may be reproduced or transmitted in any form or by any means, electronic or mechanical, including photocopying, recording, of informational storage and retrieval systems, for any purpose other than the purchaser's personal use, without the expressed written permission of Modine.

General Description – Valedictorian® Vertical Unit Ventilator

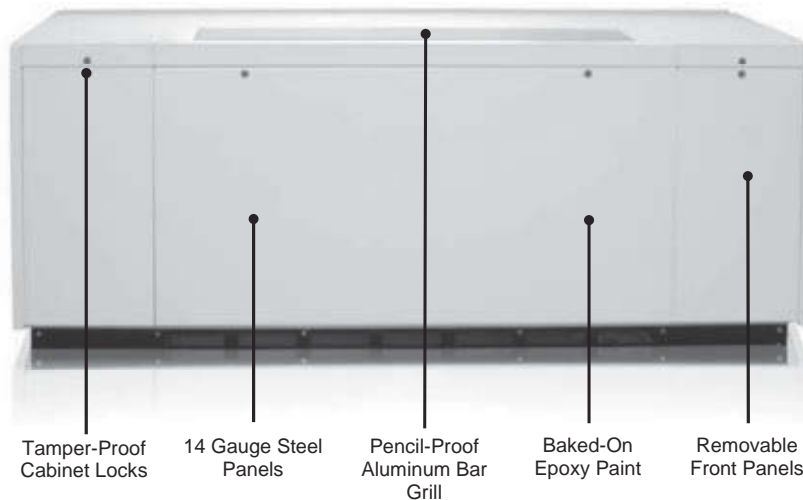

Tamper-Proof
Cabinet Locks

14 Gauge Steel
Panels

Pencil-Proof
Aluminum Bar
Grill

Baked-On
Epoxy Paint

Removable
Front Panels

STANDARD FEATURES

Overview

The Valedictorian® vertical unit ventilator is the perfect solution for both new construction and replacement of existing units in schools that want to improve the indoor air quality of their classrooms. It operates in conjunction with a schools central chiller/boiler plant and is available in Face & Bypass and Valve Control configurations. A variety of coil options and adapter backs make it easy to select the right unit for the job.

General Specification

The unit shall be a chilled water cooling/hot water heating or combined chilled water cooling and hot water heating unit ventilator. The unit shall be floor-mounted and horizontally configured with adjustable leg levelers. The unit shall have a pencil-proof clear anodized aluminum supply air bar grill and ¼" galvanized steel mesh mounted on the top panel. All access and maintenance shall be through the front and the top side panels of the unit.

The unit shall be constructed and listed in accordance with ETL and CSA standards (ANSI/UL 1995-1999, second edition) (CAN/CSA C22.2 NO 236-95).

The unit shall be constructed following ISO: 9001 quality control program procedures and be fully assembled and tested prior to shipment.

Cabinet

Prior to assembly, the cabinet parts shall be degreased and coated with a dry powder, epoxy resin paint, baked after application, standard color shall be beige with hammertone textured finish. The paint finish shall be easily cleanable and hard wearing to give maximum protection. The cabinet shall be insulated with acoustic foam insulation containing no fibrous materials. The foam insulation shall have a fire rating of UL94 HF1.

The exterior panels of the cabinet shall be constructed of 14 gauge sheet steel. Internal sheet metal shall be galvanized 16 gauge.

The front panel and compartment panels shall be easily removable with tamperproof fasteners securing it to the rest of the unit cabinet.

The back of the cabinet shall have an opening for connection to a wall sleeve and louver.

- Control Panel** The control panel is located in the left-hand compartment. All components located in the panel shall be clearly marked for easy identification. All terminal blocks and wires shall be individually numbered. All electrical wires in the control panel shall be run in an enclosed trough. Wiring outside the control panel shall be run in protective sleeves.
- The unit shall be fitted with a power disconnect switch sized for the full load amperage of the unit to enable the unit to be disconnected from the power supply prior to any maintenance.
- The 3-speed selector switch enables adjustment of the supply air volume. Reduction in fan speed shall be achieved by a step down multi-tap transformer.
- Coils** Large surface area slab coils shall be utilized to optimize heat transfer and airflow.
- Each coil shall be manufactured from refrigeration quality 3/8" diameter copper tubing mechanically bonded onto aluminum Highmix® fins with coil circuitry designed to ensure minimum waterside pressure drops. Each coil shall be fitted with an air bleed at the high point of the coil and a drain plug at the low point.
- Drain Pan** Each unit shall be fitted with a 20 gauge, 304 stainless steel welded construction drain pan sloped in 3 directions. The drain pan connection shall be reversible in the field to switch drain orientation and include 3/4" reinforced condensate tubing and splashguard over the drain port.
- Supply Fan & Fan Motor** Supply airflow shall be provided by double inlet, forward curved, centrifugal type fan with offset aerodynamic blades. The assembly shall be statically and dynamically balanced to ensure smooth running and minimum noise levels. The fan motor shall be a permanent split capacitor type complete with integral automatic thermal overload protection. The fan and motor assembly shall be direct drive type with motor and bearings positioned outside of the airstream.
- The fan assembly shall be positioned for a "draw through" configuration.
- Filter** Throwaway 1" thick filters shall be provided and installed at the factory and located to provide filtration of both the outdoor and return air prior to being conditioned.
- Dampers** Each unit shall be fitted with separate outside air and return air dampers. The dampers shall have the capability of permitting only the outside air into the space, or recycling the return air and allowing only a minimum of outside air to enter the space. Full modulation allowing any mixture of outside air and return air shall be possible. A minimum damper position setting shall also be possible to continuously maintain outside air ventilation requirements dependent on control via the unit's microprocessor controller. The outside air damper is constructed of galvanized steel and the return air damper is constructed of aluminum. Dampers shall be gasketed to prevent air bypass and shall pivot on self-lubricating nylon bearings.
- Each unit shall be fitted with an optional factory installed face & bypass damper constructed of aluminum and braced for rigidity. The damper shall include EPDM rubber end seal and F3 wool felt side seals. The damper shall be removable to allow access to the coil(s).

Options - Factory Installed

- DDC Ready Controls** Factory installed DDC ready controls shall include a fan relay, 24-volt control circuit transformer and terminal strip. Controls also include a 2-10Vdc outside air and/or face & bypass damper actuator where applicable. All components located in the panel shall be clearly marked for easy identification. All terminal blocks and wires shall be individually numbered. All electrical wires in the control panel shall be run in an enclosed trough. Wiring outside the control panel shall be run in protective sleeves.
- The unit shall be fitted with a power disconnect switch sized for the full load amperage of the unit to enable the unit to be disconnected from the power supply prior to any maintenance.
- A 3-speed selector switch shall be mounted internally enabling adjustment of the supply air volume. Reduction in fan speed shall be achieved by a step down multi-tap transformer.
- The unit shall be fitted with a freeze protection sensor mounted on the discharge side of the first coil to prevent any freezing of the first coil assembly. When the sensor detects a freeze up condition it shall shut the damper and force the flow control valve open and prevent the unit supply fan from running.
- Factory Installed Carel Controls** Factory installed Carel controls shall include a fan relay, 24-volt control circuit transformer, terminal strip and Carel microprocessor controller, return air, outside air and supply air sensors. Controls also include a 2-10Vdc outside air and/or face & bypass damper actuator where applicable. The controller is mounted outside the air stream and specifically designed to operate the unit in an energy efficient manner using pre-engineered control strategies. The microprocessor shall determine the mode of operation based on the return air, supply air and ambient air temperatures. All components located in the panel shall be clearly marked for easy identification. All terminal blocks and wires shall be individually numbered. All electrical wires in the control panel shall be run in an enclosed trough. Wiring outside the control panel shall be run in protective sleeves.
- The unit shall be fitted with a power disconnect switch sized for the full load amperage of the unit to enable the unit to be disconnected from the power supply prior to any maintenance.
- A 3-speed selector switch shall be mounted internally enabling adjustment of the supply air volume. Reduction in fan speed shall be achieved by a step down multi-tap transformer.
- The unit shall be fitted with a freeze protection sensor mounted on the discharge side of the first coil to prevent any freezing of the first coil assembly. When the sensor detects a freeze up condition it shall shut the damper and force the flow control valve open and prevent the unit supply fan from running.
- Carel Controls – Lonworks Plug-In Card** The Carel microprocessor controls shall come equipped with a plug-in card allowing for complete compatibility with FT-10 Lonworks control system.
- Carel Controls – BACnet Plug-In Card** The Carel microprocessor controls shall come equipped with a plug-in card allowing for complete compatibility with an MS/TP BACnet control system.
- Carel Time Clock / Card** A time clock (card) shall be provided for “stand-alone” units where time functions, night and weekend setback, etc. are not transmitted from a building management system or remote central time clock. The time clock shall have a full 7 day schedule and calendar function incorporated. The 7 day schedule shall have two adjustable occupied/unoccupied periods per day. The calendar function shall allow 20 calendar periods (start date / stop date = 1 period).
- Carel Display Module** For units fitted with the Carel microprocessor controller, a hand-held display module shall be supplied for set point changes, control adjustments, error acknowledgement and unit troubleshooting.

CO₂ Sensor	The CO ₂ sensor shall be mounted in the interior return air passage of the unit to provide demand ventilation. When the level of CO ₂ rises over a predetermined set point, the sensor shall proportionally adjust the minimum damper position to allow larger quantities of outside air into the room. The sensor shall have the capability of measuring CO ₂ levels from 0 to 2,000 ppm with an accuracy of + 40 ppm CO ₂ + 3.0% of the reading.
Aquastat	An aquastat shall be fitted to two pipe systems to prevent changeover into a heating mode when cooling is required and vice-versa.
Condensate Pump	The unit shall be fitted with a condensate pump. The pump shall have a 1/30 th hp motor capable of 20 gph at 15 feet of lift with rustproof, ABS plastic tank with built-in flow check valve and safety switch.
Condensate Pan Float Switch	The unit shall be fitted with a float switch mounted on the condensate pan to stop the cooling function should the condensate rise to a predetermined level.
Fire Detection	The unit shall be fitted with a liquid element fire detection mounted in the return air stream to prevent the unit from operating if the return air temperature should rise above the setting on the element. The temperature setting on the fire detector element shall be adjustable.
Smoke Detector	The unit shall be fitted with a smoke detector mounted in the return air stream. If smoke is present the unit will be shut down automatically.
Carel Room Sensor	For units fitted with the Carel microprocessor controller, a temperature sensor and set point adjustment module with override button shall be furnished for wall mounting.
Carel Thermostat	For units fitted with the Carel microprocessor controller, a digital thermostat shall be furnished for wall mounting.
Insulated Damper Assembly	The outside air damper shall be insulated with ½" thick insulation to inhibit condensation on the damper surface.
EC Motor	The fan motor shall be an electronically commutated motor (ECM). The ECM provides constant airflow by automatically adjusting the speed if the external static pressure changes. The DC motor features a brushless, permanently lubricated ball bearing construction for maintenance free operation. The ECM shall also be fully programmed to compensate for a wide variety of static pressures as well as lack of maintenance (dirty air filters).

Accessories - Field Installed

Modulating Control Valve	Two-way or three-way modulating valve(s) shall be provided for precise capacity control of hot water and/or chilled water coil(s). The capacity control valve(s) shall be controlled by a 2-10Vdc signal from the unit mounted controller and shipped loose for field installation.
2-Position Spring Return Control Valve	Two-way or three-way 2-position spring return control valve(s) shall be provided for control of hot water and/or chilled water coil(s). The control valve(s) shall be controlled by a 24V signal from the units control panel and shipped loose for field installation.
Balancing Valve	A heavy duty forged brass ball-valve construction balancing valve shall be supplied loose for field installation.
Circuit Setter	A manually adjustable ball-valve construction balancing valve with Schrader style pressure ports and drain port shall be supplied loose for field installation.
Drain with Hose Bib	A blowdown valve with hose connector and cap shall be mounted on the coil.
Shut-Off Valves	A set of two heavy duty forged brass ball valves, one for the supply and one for the return, shall be supplied loose for field installation.
Strainer	A heavy duty cast iron strainer with 20 mesh 304 stainless steel screen, gasketed and tapped retainer cap and blow-off outlet shall be supplied loose for field installation.
Factory Assembled Piping	The selected piping components shall be factory assembled, with all the necessary piping and unions, and shipped separately to be field installed inside the side compartment and outside of the airstream of the unit ventilator.
Factory Installed Valve by Others	Modine shall factory install a hot water and/or chilled water control valve into the factory assembled piping, subject to the available mounting space. The valve(s) shall be supplied by others and shipped to the factory prior to unit production.
Side Panels	Factory supplied side panels constructed of 14 gauge sheet steel and painted to match the unit shall be field mounted to the base unit. Side panels are available for both 16 5/8" and 21 7/8" deep units with or without pipe passage cutouts.
Utility Compartment	A factory supplied utility compartment with 14 gauge sheet steel front and top panels and painted to match the unit shall be field mounted to the base unit. Utility compartments are available for both 16 5/8" and 21 7/8" deep units in 12", 18" and 24" widths.
Filler Section	A factory supplied filler section constructed of 16 gauge sheet steel and painted to match the unit shall be field mounted. Filler sections are available in 6", 12" and 18" widths and can be field cut for custom widths.
Unit Sub-Base	Unit height adjustments can be made in increments of 1", 2", 4" and 6" with a sub-base field mounted under the standard unit. The sub-base is fully enclosed, constructed of heavy duty steel and painted to match the base of the standard unit.
Utility Compartment Sub-Base	Utility compartment height adjustments can be made in increments of 1", 2", 4" and 6" with a sub base field mounted under the standard utility compartment. The sub base is fully enclosed, constructed of heavy duty steel and painted to match the base of the standard utility compartment.
Wall Sleeve	The wall sleeve shall be constructed from galvanized steel. The sleeve shall be provided by Modine and insulated by the installing contractor with foil back insulation.

- Outdoor Louver** An outdoor louver shall be furnished by Modine and be suitable for masonry, glass, or panel wall construction. The louvers are flanged style with 42 degree, .040 thick blades with 0.775 inch blade spacing and shall be available in the following materials:
1. Aluminum with clear anodized finish
 2. Aluminum with baked enamel finish, customer selected from manufacturer's standard louver color chart
- All louvers can be provided with a bird screen
- Duct Flange** A 1" duct flange shall be supplied and field installed to allow for easy installation of a supply air duct to the unit.
- Spare Filters** One spare filter shall be supplied with the unit.

Figure 9.1 – Component Layout

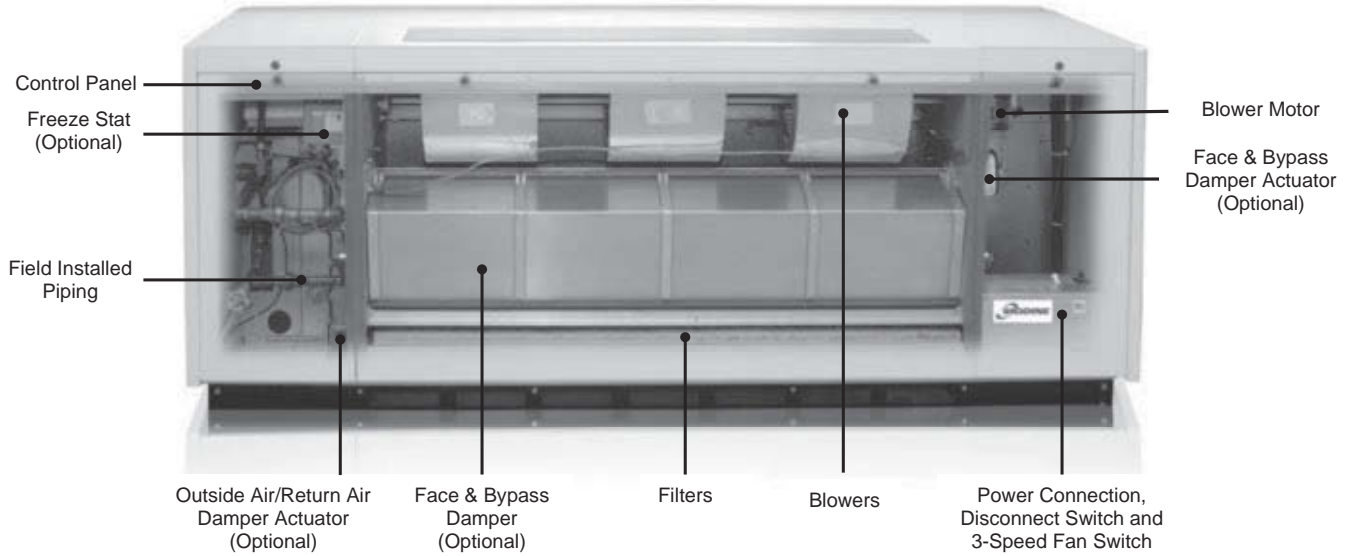

Valve Control Units

In a Valve Control Unit all of the air passes through the coil. The flow of water through the coil is modulated to maintain the set point temperature in the room.

1. Air is drawn through the unit by the blowers (draw-through design), conditioned and supplied to the room.
2. Return air enters through the lower front kick panel of the unit and outside air enters through the lower back panel of the unit.
3. The percentage of outside air and return air is controlled by the position of the outside air and return air dampers.
4. Air passes through the filters and then through the coil. The air is conditioned as it passes through the coil.
5. Cooling or heating is controlled by adjusting the flow of water through the coil with a modulating valve.

Figure 10.1 – Valve Control Unit

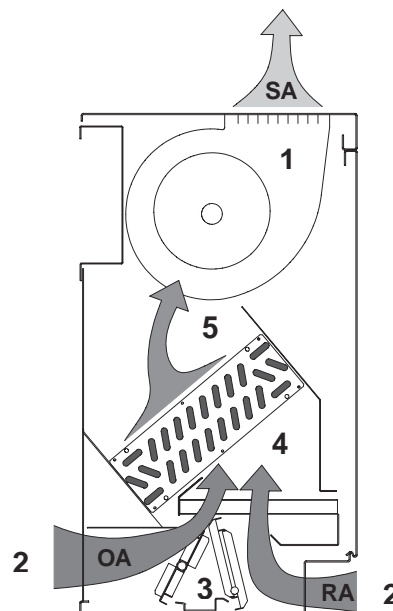

Face & Bypass Units

In a Face & Bypass Unit the outside air and return air can be separated, to condition only the outside air, or mixed before passing through the coil. Water flow and coil temperature remain constant to provide maximum dehumidification and low risk of coil freezing. The face & bypass damper is modulated to maintain the set point temperature in the room.

1. Air is drawn through the unit by the blowers (draw-through design), conditioned or bypassed and supplied to the room.
2. Return air enters through the lower front kick panel of the unit and outside air enters through the lower back panel of the unit.
3. The percentage of outside air and return air is controlled by the outside air and return air dampers.
4. Air passes through the filters and then either passes through the coil or is diverted to bypass the coil. The air passing through the coil is conditioned. Bypassed air is mixed with the conditioned air and delivered to the room.
5. Cooling or heating is controlled by adjusting the face & bypass damper.

Figure 10.2 – Face & Bypass Unit

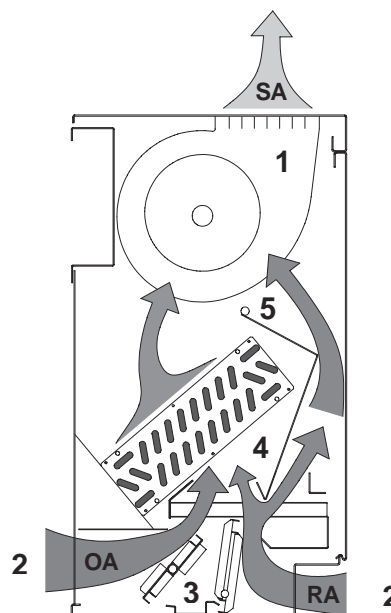

Figure 11.1 - Dimensional Data – 16 5/8” Unit

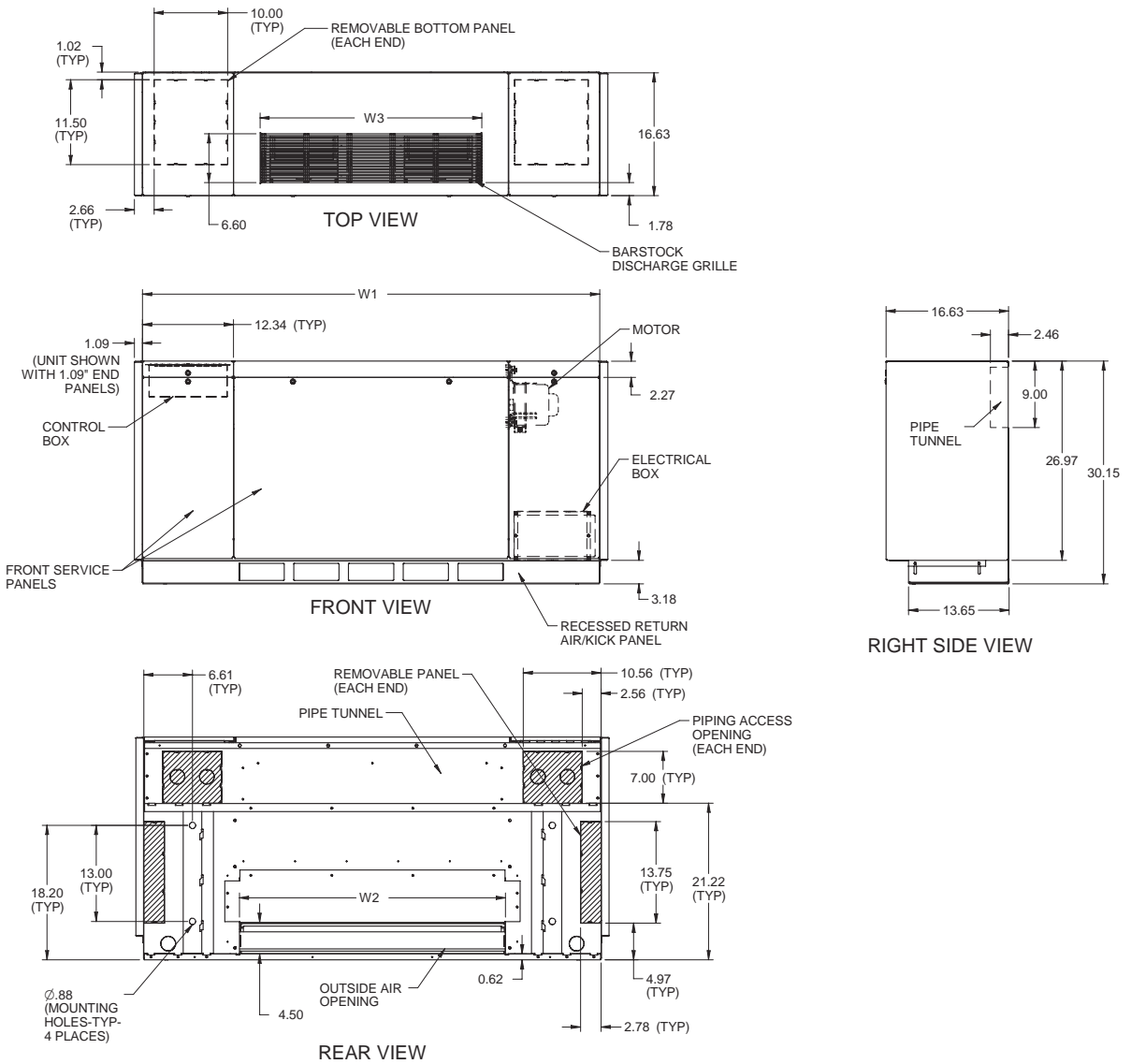

Table 11.1 – Unit Width Dimensions

Model Size	Dimensions (inches)		
	W1	W2	W3
750	62	36	30
1000	74	48	42
1250	86	60	54
1500	98	72	66

Figure 12.1 - Dimensional Data – 21 7/8” Unit

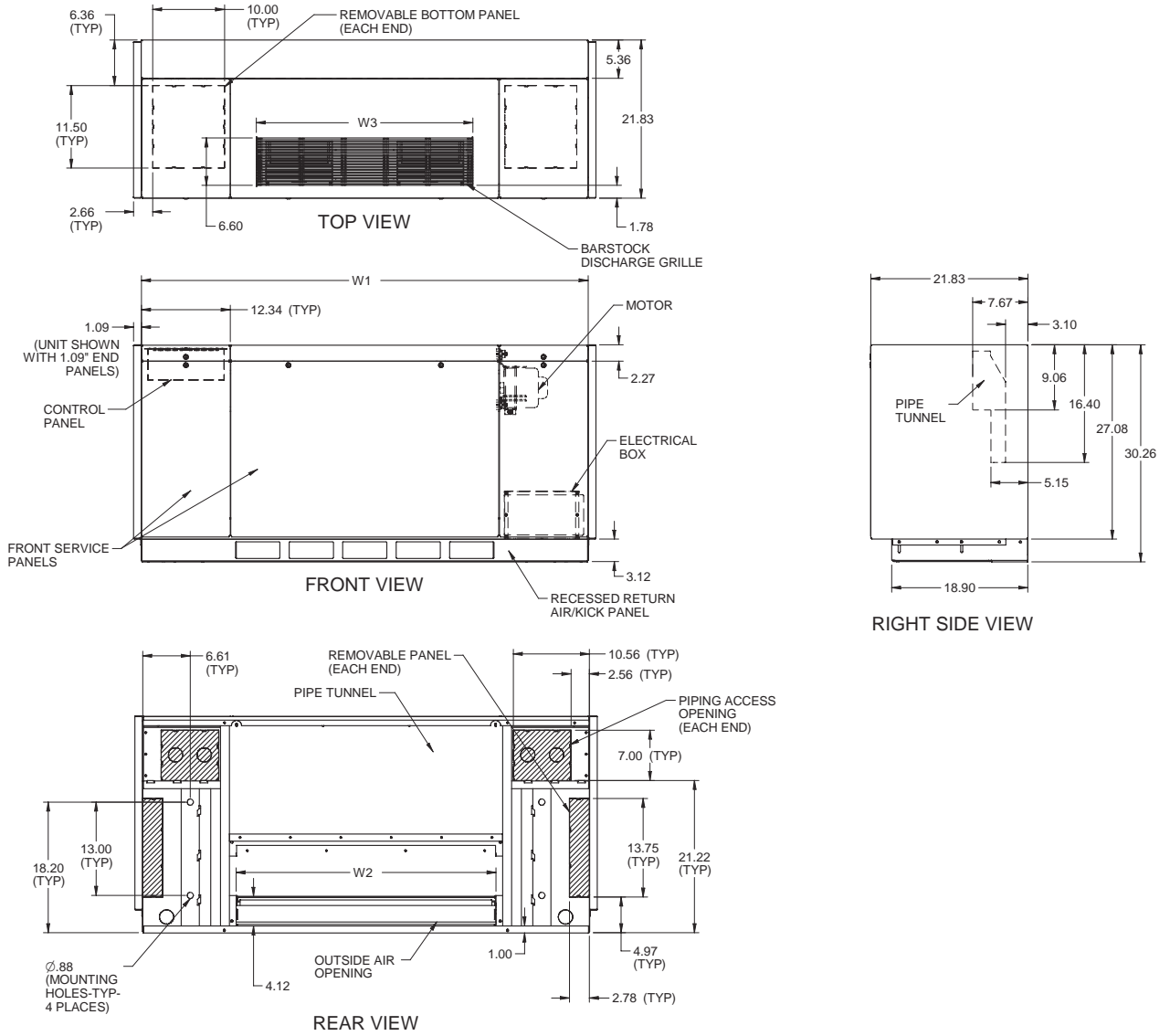
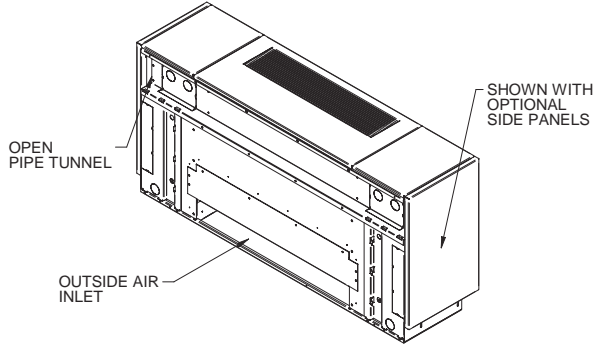

Table 12.1 – Unit Width Dimensions

Model Size	Dimensions (inches)		
	W1	W2	W3
750	62	36	30
1000	74	48	42
1250	86	60	54
1500	98	72	66

Figure 13.1 - Inlet Air Arrangements for 16 5/8" Units

A. Rear Outside Air – Open Pipe Tunnel



B. Rear Outside Air – Closed Pipe Tunnel

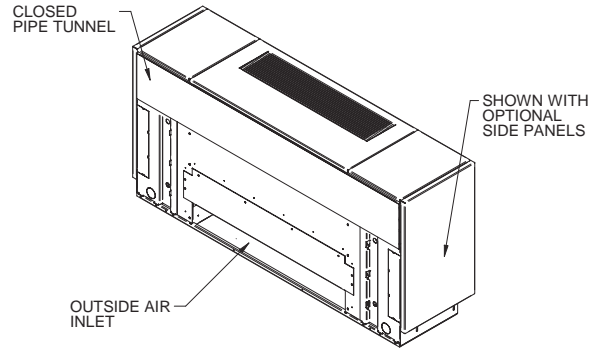

C. Bottom Outside Air – Open Pipe Tunnel

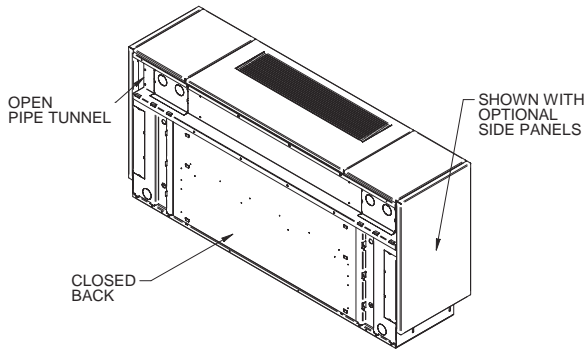

D. No Outside Air – Open Pipe Tunnel

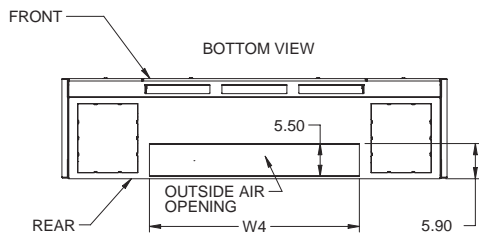
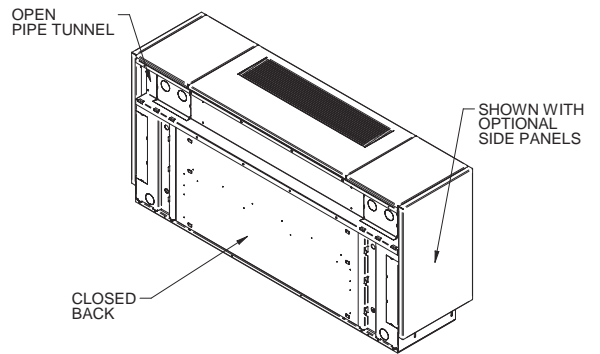
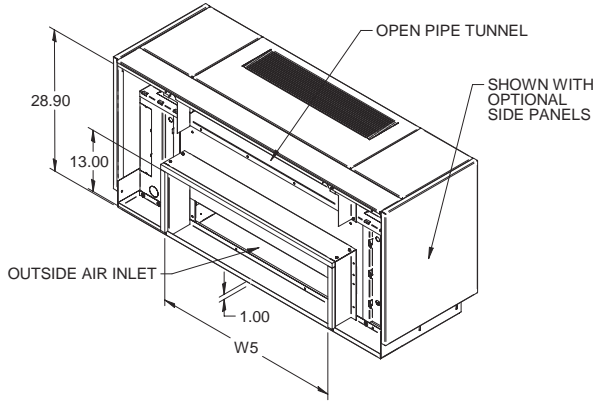

Table 13.1 – Unit Width Dimensions

Model Size	Dimensions (inches)
	W4
750	35
1000	47
1250	59
1500	71

Figure 14.1 - Inlet Air Arrangements for 21 7/8” Units

E. Rear Outside Air – Open Pipe Tunnel



F. Rear Outside Air – Closed Pipe Tunnel

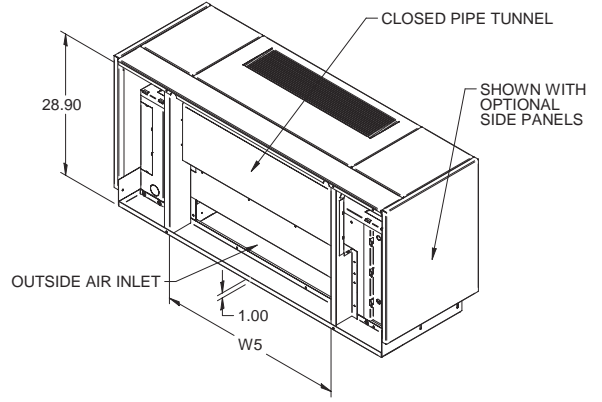

G. Top Window Intake – Closed Pipe Tunnel

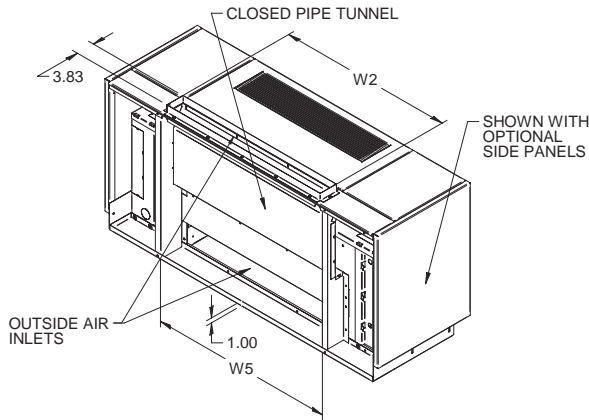

H. Bottom Outside Air – Closed Pipe Tunnel

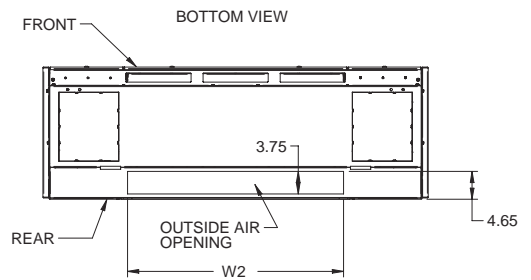
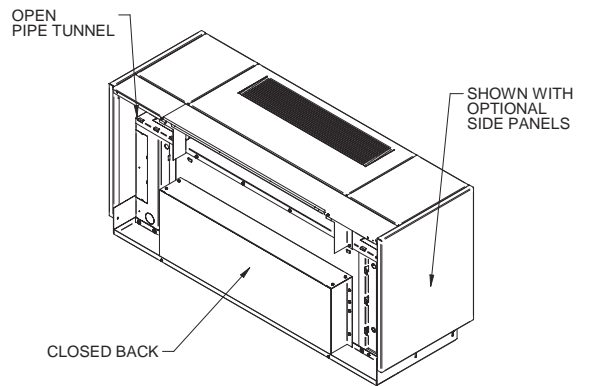
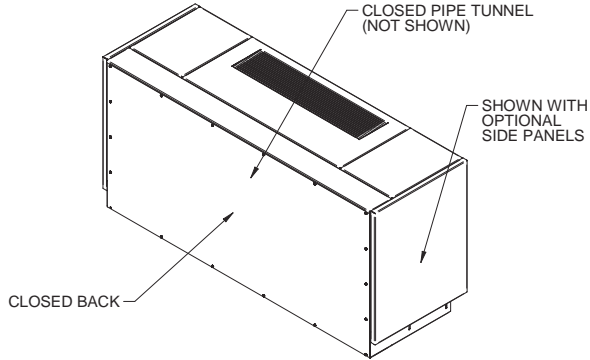

Table 14.1 – Unit Width Dimensions

Model Size	Dimensions (inches)	
	W2	W5
750	36	38
1000	48	50
1250	60	62
1500	72	74

Figure 15.1 - Inlet Air Arrangements for 21 7/8” Units

J. Closed Back – Closed Pipe Tunnel



K. 2” Step-Down – Open Pipe Tunnel

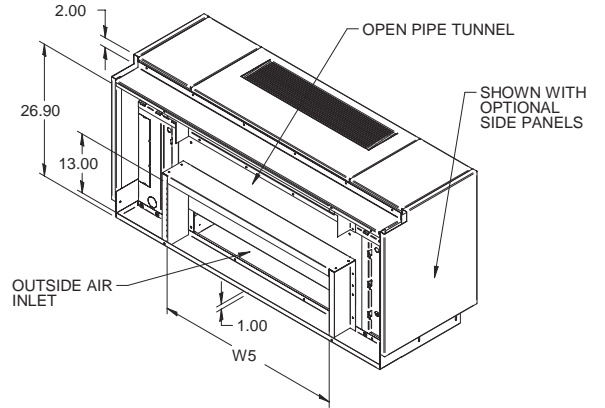

L. 2” Step-Down – Closed Pipe Tunnel

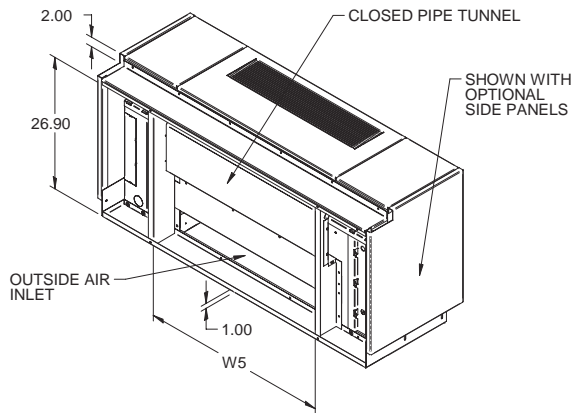

Table 15.1 – Unit Width Dimensions

Model Size	Dimensions (inches)
	W5
750	38
1000	50
1250	62
1500	74

Figure 16.1 - Piping Connection Locations

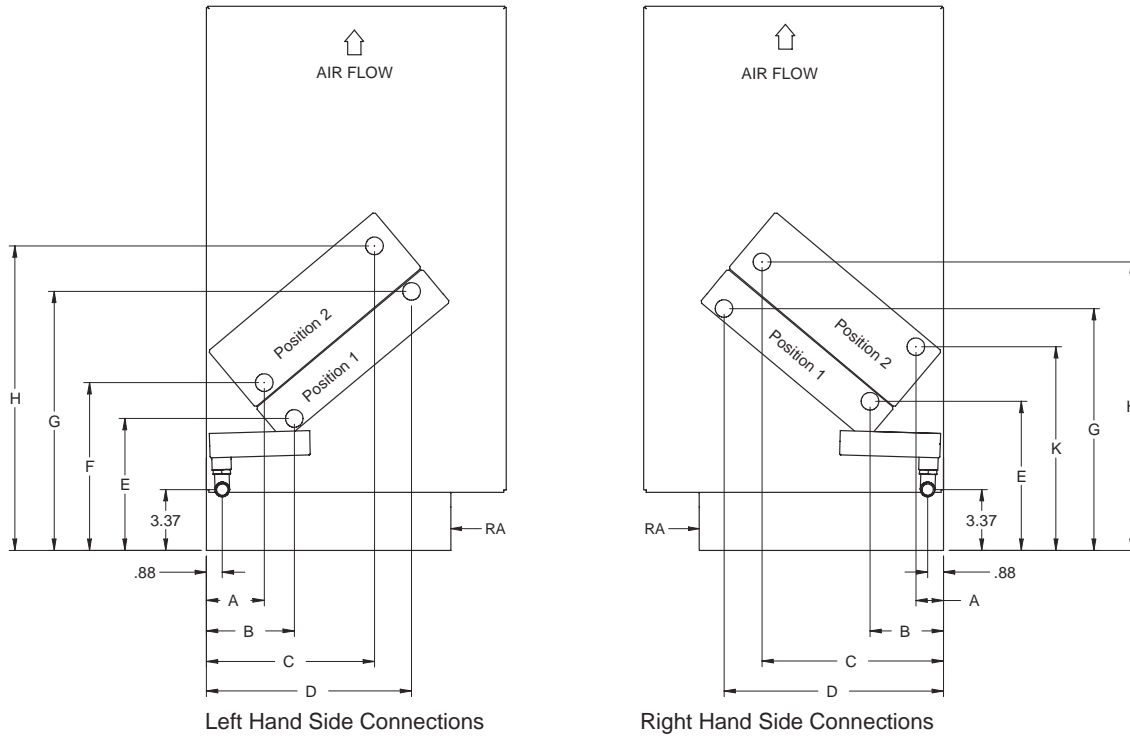

Table 16.1 – Piping Connection Locations

		Dimensions (inches)							
		Supply				Return			
Left Side		A	B	E	F	C	D	G	H
Position 1	1 Row Coil		5.00	7.00			11.50	14.25	
	2 Row Coil		4.75	7.25			11.25	14.25	
	3 Row Coil		4.75	7.50			11.00	15.00	
	4 Row Coil		4.75	7.50			11.00	15.00	
Position 2	1 Row Coil	2.25			10.25	8.75			17.50
	2 Row Coil	2.25			10.50	8.75			17.50
	3 Row Coil	2.75			10.00	8.75			17.50
	4 Row Coil	3.25			9.25	9.25			16.75
Right Side		A	B	E	F	C	D	G	H
Position 1	1 Row Coil		4.00	8.25			12.00	13.50	
	2 Row Coil		4.00	8.25			12.25	13.50	
	3 Row Coil		3.50	8.75			12.00	13.50	
	4 Row Coil		3.00	9.50			11.75	14.00	
Position 2	1 Row Coil	1.25			11.50	9.50			16.75
	2 Row Coil	1.50			11.50	9.50			16.50
	3 Row Coil	1.50			11.25	10.00			16.00
	4 Row Coil	1.50			11.25	10.00			16.00

Coil Positions

Units with one coil (heating only, cooling only or 2-pipe heating & cooling) – coil is mounted in Position 1
 Preheat units – heating coil is mounted in Position 1 and cooling coil is mounted in Position 2
 Reheat units – cooling coil is mounted in Position 1 and heating coil is mounted in Position 2

Coil Connections

All coils supplied with unions with 3/4" female solder joint for supply and return connections

Table 17.1 – Cooling Capacity (Btu/Hr)^①

Unit Size	EWT (°F)	Flow Rate (GPM)	Number of Rows	PD (ft)	Capacity Type (Btu/Hr)	Airflow CFM		
						High	Medium	Low
						Entering Air Temp (EDB/EWB °F)		
						80/67		
750	45	6	2	2.32	Total	18,312	17,071	14,694
					Sensible	14,965	13,694	11,464
			3	1.14	Total	26,160	24,388	20,991
					Sensible	18,707	17,118	14,330
			4	1.27	Total	27,520	25,656	22,083
					Sensible	19,109	17,486	14,639
		10	2	6.14	Total	21,297	19,255	16,392
					Sensible	16,533	14,908	12,508
			3	3.02	Total	30,424	27,508	23,417
					Sensible	20,666	18,635	15,635
			4	3.36	Total	32,006	28,938	24,634
					Sensible	21,110	19,036	15,971
1000	45	6	2	3.11	Total	27,859	24,376	21,468
					Sensible	22,876	19,163	16,439
			3	1.56	Total	32,775	28,678	25,256
					Sensible	24,080	20,172	17,304
			4	3.94	Total	34,454	30,147	26,550
					Sensible	24,461	20,490	17,578
		10	2	8.32	Total	32,099	28,494	25,835
					Sensible	25,955	21,442	19,026
			3	4.16	Total	37,763	33,523	30,394
					Sensible	27,321	22,571	20,028
			4	10.52	Total	39,698	35,240	31,951
					Sensible	27,752	22,927	20,344
1250	45	6	2	4.02	Total	32,871	28,391	25,135
					Sensible	27,608	22,624	19,635
			3	1.98	Total	38,671	33,401	29,571
					Sensible	29,061	23,814	20,668
			4	2.00	Total	40,652	35,112	31,085
					Sensible	29,520	24,191	20,995
		10	2	10.83	Total	39,623	32,737	29,067
					Sensible	30,868	24,748	21,672
			3	5.33	Total	46,616	38,514	34,197
					Sensible	32,493	26,050	22,813
			4	5.38	Total	49,004	40,487	35,949
					Sensible	33,006	26,462	23,173
1500	45	6	2	4.95	Total	37,455	32,871	29,721
					Sensible	32,186	26,797	23,503
			3	2.45	Total	44,064	38,672	34,966
					Sensible	33,880	28,207	24,740
			4	2.45	Total	46,356	40,683	36,784
					Sensible	34,601	28,808	25,267
		10	2	13.37	Total	45,709	38,736	34,125
					Sensible	36,205	29,616	25,637
			3	6.62	Total	53,775	45,572	40,147
					Sensible	38,111	31,175	26,987
			4	6.62	Total	56,572	47,942	42,235
					Sensible	38,922	31,839	27,562

① For additional capacity information, please consult the Breeze AccuSpec software.

Table 18.1 – Heating Capacity (Btu/Hr)^①

Unit Size	EWT (°F)	Flow Rate (GPM)	Number of Rows	PD (ft)	Airflow CFM					
					High	Medium	Low			
					Heating Return Air Temp (EDB °F)					
					60					
750	160	6	1	0.88	38386	34752	28560			
			2	1.78	50110	45366	37283			
			3 ②	0.82	57261	51840	42604			
			4 ②	0.86	61152	55363	45499			
		10	1	2.32	41823	37438	30477			
			2	4.71	54596	48872	39786			
			3 ②	2.17	62388	55847	45463			
			4 ②	2.28	66627	59642	48553			
			1000	160	6	1	1.16	49804	40803	34395
						2	2.35	62381	51107	43080
3 ②	1.09	72442				59350	50029			
4 ②	1.14	81135				66472	56032			
10	1	3.07			54685	44005	36773			
	2	6.2			68494	55118	46059			
	3 ②	2.87			79541	64008	53488			
	4 ②	3.01			89086	71689	59906			
	1250	160			6	1	1.45	59656	47744	41610
						2	2.93	77550	62065	54091
3 ②			1.36	88437		70778	61684			
4 ②			1.43	99226		79413	69210			
10			1	3.82	66035	51738	44724			
			2	7.71	85843	67258	58139			
			3 ②	3.57	97893	76700	66300			
			4 ②	3.75	109836	86057	74389			
			1500	160	6	1	1.75	70109	57236	49403
						2	3.52	92625	75619	65269
3 ②	1.63	103573				84557	72984			
4 ②	1.71	108959				88594	76779			
10	1	4.58			78277	62508	53391			
	2	9.24			103417	82584	70539			
	3 ②	4.28			115640	92344	78876			
	4 ②	4.49			121653	97146	82978			

① For additional capacity information, please consult the Breeze AccuSpec software.

② 2-pipe chilled water / hot water units

Table 18.2 – Sound Data

Model	750			1000			1250			1500		
Speed	L	M	H	L	M	H	L	M	H	L	M	H
CFM	500	650	750	600	750	1000	750	900	1250	900	1100	1500
dBA	55.7	62.8	66.5	56.2	61.5	68.4	57.0	61.4	69.8	61.3	66.1	73.3

Notes:

1. Rated in accordance with ARI Standard 350-2008.
2. Sound power levels were recorded using ARI standard 220-2007 method.
3. Sound power levels were recorded with the unit running in full recirculation mode and a 3 row coil.

Table 19.1 – Technical Data

VFF & VFFV	Units	750	1000	1250	1500
SUPPLY FAN		Direct Drive Centrifugal			
Fan Quantity		2	3	4	4
Fan Diameter		8.06	8.06	8.06	8.06
Fan Width		7.15	7.15	7.15	7.15
Motor Size (Qty 1)	hp	1/4	1/4	1/4	1/4
Motor Type		PSC with Thermal Overload Protection			
Airflow (High/Medium/Low)	cfm	750/650/500	1000/750/600	1250/900/750	1500/1100/900
Max External Static Pressure	in.Wg	0.05	0.05	0.05	0.05
COIL WATER VOLUME					
1 Row	gal	0.32	0.38	0.44	0.50
2 Row	gal	0.51	0.63	0.76	0.88
3 Row	gal	0.72	0.91	1.10	1.28
4 Row	gal	0.92	1.17	1.42	1.66
CONNECTIONS - Coil		Unions with 3/4" female solder joint			
Condensate Line	Inches	3/4" ID condensate line			
UNIT WEIGHT (approximate)					
Shipping Weight – 16 5/8" Units	lbs.	375	420	470	520
Operating Weight – 16 5/8" Units	lbs.	320	365	410	450
Shipping Weight – 21 7/8" Units	lbs.	425	480	540	600
Operating Weight – 21 7/8" Units	lbs.	370	425	480	530
FILTER		1" Woven Fiberglass, 70-75% Arrestance			
Quantity		1	2	2	2
Dimensions	in.	10 X 36	10 X 24	10 X 30	10 X 36

Table 19.2 – Chilled Water Cooling Capacity

Model	750		1000		1250		1500	
	Total	Sensible	Total	Sensible	Total	Sensible	Total	Sensible
2	18,494	15,985	26,570	22,239	34,943	28,620	43,437	35,037
3	24,248	17,914	34,532	24,829	45,124	31,894	55,621	38,942
4	26,248	18,499	37,404	25,651	48,576	32,845	59,662	40,230

Notes:

1. Rated in accordance with ARI Standard 840.
2. Water temperature rise is 10°F, with entering water temperature of 45°F.
3. Entering air temperature is 80°F dry bulb, 67°F wet bulb.

Table 19.3 – Hot Water Heating Capacity

Model	750	1000	1250	1500
Rows	Btu/h	Btu/h	Btu/h	Btu/h
1	38,386	49,804	59,656	70,109
2	50,110	62,381	77,550	92,625
3	57,261	72,442	88,437	103,573
4	61,152	81,135	99,226	108,959

Notes:

1. Water temperature is 160°F and 6 gpm water flow.
2. Entering air temperature is 60°F.

Table 19.4 – Electrical Data

Motor Size	115V			208V			230V		
	FLA	MCA	MOP	FLA	MCA	MOP	FLA	MCA	MOP
1/4 Hp Motor (Standard)	3.1	3.7	15	1.7	2.1	15	1.5	1.9	15
1/4 Hp Motor with Condensate Pump	4.8	5.4	15	2.6	3.0	15	2.4	2.8	15
1/2 Hp EC Motor	8.4	10.4	15	4.6	5.7	15	4.5	5.5	15
1/2 Hp EC Motor with Condensate Pump	10.1	12.1	15	5.6	6.7	15	5.4	6.4	15

Controls

Field Installed Controls by Others (Standard)

Units come standard with a blower motor, a power disconnect switch and a 3-speed selector switch for adjustment of the supply air volume. All other controls, sensors and actuators must be supplied by others.

Factory Installed DDC Ready Controls (Optional)

In addition to the blower motor, power disconnect and 3-speed selector switch; the optional factory installed DDC ready controls include a fan relay, 24-volt control circuit transformer, coil freeze protection sensor and terminal strip. Controls also include a 2-10Vdc outside air and/or face & bypass damper actuator where applicable.

Factory Installed Carel Controls (Optional)

Units include the Factory Installed DDC Ready Controls listed above along with a Carel microprocessor controller, return air sensor, outside air sensor and supply air sensor. The microprocessor shall determine the mode of operation based on the return air, supply air and ambient air temperatures.

Control Sequence

Supply Fan

The supply fan shall run at all times when unit is in occupied mode. When in unoccupied mode, the supply fan shall run only on a call for heating or cooling. The supply fan speed can be adjusted using the standard equipped manual 3-speed switch. If equipped with a Carel controller, the supply fan is programmed to run for 2 minutes (adjustable) after the heating or cooling cycle ends.

Freeze Stat

On units equipped, an adjustable auto-resetting freeze stat is factory set to trip at 35°F. If the coil temperature reaches the limit and the freeze stat trips, it shall reset when the coil temperature rises 5°F above the setpoint. The freeze stat shall be wired so that upon tripping, power is removed from the supply fan, the outside air damper closes, and either the HW valve opens or the face & bypass damper goes to full bypass (depending on how unit is equipped).

Outside Air and Return Air Dampers

The outside air and return air dampers control the mixture of return air and outside air drawn through the unit. Both dampers are linked together and are controlled by an actuator requiring a 2-6VDC proportional signal. At 2V, the dampers are positioned for full return air and no outside air. At 6V, the dampers are positioned for full outside air and no return air. The outside air damper shall open to a minimum position to provide ventilation requirements when the room is occupied. When in heating mode, if the space temperature is more than 4°F from the heating setpoint, the outside air damper shall fully close. The outside air damper shall also be fully closed during unoccupied mode. If the unit is equipped with a CO₂ sensor, the outside air damper shall modulate open proportionally to compensate for the CO₂ levels in the room.

The dampers can act as economizers for free-cooling. If cooling is required and the outside air temperature is below the economizer outside air lockout temperature (recommended 60°F) and above 35°F, the outside air damper shall modulate open. On units with a Carel controller, the outside air damper shall fully open when the room temperature is above the setpoint by more than 1°F (adjustable). Within 1°F, the proportional band adjusts the outside air damper. When the unit is in free-cooling, water valves shall be fully closed, and if equipped, the face & bypass damper should move to full bypass position. The outside air lockout temperature on Carel units is factory set to 60°F and is adjustable.

Control Sequence Continued

Chilled Water with Valve Control

Units with a chilled water coil and non-Carel controls desiring valve control shall use a non-spring return modulating valve operated by either a proportional (2-10VDC) or a tri-state (24VAC) signal. Units with a chilled water coil and Carel controls desiring valve control shall use a modulating valve requiring a tri-state signal. When the room temperature is above the cooling setpoint, the valve shall open proportionally according to the adjustable proportional band. The adjustable proportional band on the Carel controller is set to a default 1°F (ex. valve is 50% open when room temperature is 0.5°F from setpoint). The Carel controller will not allow the chilled water valve to open when the outside air temperature is below 55°F.

Hot Water with Valve Control

Units with a hot water coil and non-Carel controls desiring valve control shall use a spring-return, normally open modulating valve operated by a proportional signal (2-10VDC) or a tri-state (24VAC) signal. Units with a hot water coil and Carel controls desiring valve control shall use a modulating control valve with a proportional signal. When the room temperature is below the heating setpoint, the valve shall open proportionally according to the adjustable proportional band. The adjustable proportional band on the Carel controller is set to a default 1°F (ex. valve is 50% open when room temperature is 0.5°F from setpoint). If for any reason the supply air temperature drops below 55°F, the hot water valve shall modulate open to maintain 55°F.

Chilled Water with Face & Bypass Control

Units equipped with a chilled water coil and face & bypass control shall modulate the face & bypass damper via a spring return actuator, controlled by a proportional signal (2-5.5V). The face & bypass damper regulates the amount of return air and outside air passing through the chilled water coil. On a call for cooling, the damper shall open to the face of the coil proportionally based on how many degrees the room temperature is from the setpoint. The adjustable proportional band on the Carel controller is set to a default 1°F (ex. damper is 50% open when room temperature is 0.5°F from setpoint). When the damper is in full bypass position (2V), all return and outside air bypasses the chilled water coil. When the damper is in full face position (5.5V), all return and outside air passes through the chilled water coil.

Hot Water with Face & Bypass Control

Units equipped with a hot water coil and face & bypass control shall modulate the face & bypass damper via a spring return actuator, controlled by a proportional signal (2-5.5V). The face & bypass damper regulates the amount of return air and outside air passing through the hot water coil. On a call for heating, the damper shall open proportionally based on how many degrees the room temperature is from the setpoint. The adjustable proportional band on the Carel controller is set to a default 1°F (ex. damper is 50% open when room temperature is 0.5°F from setpoint). When the damper is in full bypass position (2V), all return and outside air bypasses the hot water coil. When the damper is in full face position (5.5V), all return and outside air passes through the hot water coil. If for any reason the supply air temperature drops below 55°F, the hot water valve shall open (if equipped) and the face and bypass damper shall modulate to maintain 55°F.

Hot Water and Chilled Water (2-Pipe) with Valve Control

Units desiring valve control to provide heating and cooling on a single water coil (2-pipe system) and not using Carel controls shall use a spring-return, normally open modulating valve operated by a proportional signal (2-10VDC) or a tri-state (24VAC) signal. Units with Carel controls shall use a modulating control valve with a proportional signal. On a call for heating or cooling (depending on the season), the valve shall open proportionally based on how many degrees the room temperature is from the setpoint. The adjustable proportional band on the Carel controller is set to a default 1°F (ex. valve is 50% open when room temperature is 0.5°F from setpoint). If for any reason the supply air temperature drops below 55°F, the water valve shall modulate open to maintain 55°F. On 2-pipe units not having Carel controls or not connected to a network, an optional aquastat is recommended to prevent inadvertent changeover of heating/cooling modes.

Control Sequence Continued

Hot Water and Chilled Water (2-Pipe) with Face & Bypass Control

Units desiring face and bypass control to provide heating and cooling on a single water coil (2-pipe system) shall modulate the face & bypass damper via a spring return actuator, controlled by a proportional signal (2-5.5V). The face & bypass damper regulates the amount of return air and outside air passing through the water coil. On a call for heating or cooling (depending on the season), the damper shall open proportionally based on how many degrees the room temperature is from the setpoint. The adjustable proportional band on the Carel controller is set to a default 1°F (ex. damper is 50% open when room temperature is 0.5°F from setpoint). When the damper is in full bypass position (2V), all return and outside air bypasses the water coil. When the damper is in full face position (5.5V), all return and outside air passes through the water coil. If for any reason the supply air temperature drops below 55°F, the water valve shall open (if equipped) and the face and bypass damper shall modulate to maintain 55°F.

2-Position Control Valves

Optional spring-return, 2-position control valves can be used to control the end of cycle flow on both chilled and hot water coils. On a chilled water coil, a normally closed valve is used. On a hot water coil or 2-pipe changeover system, a normally open valve is used.

The 2-position valve used on a chilled water coil shall open on a call for cooling when the outside air temperature is greater than 55°F. When the outside air temperature is less than 55°F, the valve should remain closed and free cooling shall be utilized. The 2-position chilled water valve shall be closed when the 2-position hot water valve is open (when equipped). The valve is controlled by a 24VAC digital output.

The 2-position valve used on a hot water coil shall open on a call for heating. The valve shall always open when the outside air temperature drops below 40°F. This is to prevent the coil from freezing or nuisance tripping of the freeze stat. The 2-position hot water valve shall be closed when the 2-position chilled water valve is open (if equipped). The valve is controlled by a 24VAC digital output.

The 2-position valve used on a 2-pipe changeover system shall operate like the 2-position chilled water valve in cooling mode, and like the 2-position hot water valve in heating mode.

Condensate Pump

On units equipped with a condensate pump, the pump shall begin to run once the condensate reaches a set level. The pump comes with an internal safety switch that can be wired either normally open or normally closed. The safety switch shall be wired such that the chilled water valve closes when it trips. On Carel units, the switch shall be wired normally closed into a digital input of the controller. If the unit is also equipped with a condensate pan float switch, both switches shall be wired in series.

Condensate Pan Float Switch

On units equipped with a condensate pan float switch, the normally closed switch shall be wired such that the chilled water valve closes upon tripping. On Carel units, the switch shall be wired normally closed into a digital input of the controller. If the unit is also equipped with a condensate pump, both the condensate pump limit switch and condensate pan float switch shall be wired in series.

CO₂ Sensor

An optional CO₂ sensor with a range of 0-2000 ppm producing an output signal of 0-20mA is available to modulate the outside air damper. If equipped, the outside air damper shall modulate open proportionally to compensate for the CO₂ levels in the room. On Carel units, if the CO₂ level is 800 ppm or less, the damper shall remain at its normal minimum position. If the CO₂ level increases above 800 ppm, the damper begins to open according to the proportional band. The proportional band is set to a default of 200 ppm and is adjustable. Using the default, once the CO₂ level reaches 1000 ppm, the damper shall be at its maximum ventilation position.

Fire Detector

Units equipped with an optional fire detector shall shut down power to the supply fan and close all dampers upon the detection of a fire.

Smoke Detector

Units equipped with an optional smoke detector shall shut down power to the supply fan and close all dampers upon the detection of smoke.

Figure 23.1 - Side Panels

D = 16 5/8 or 21 7/8 Inches

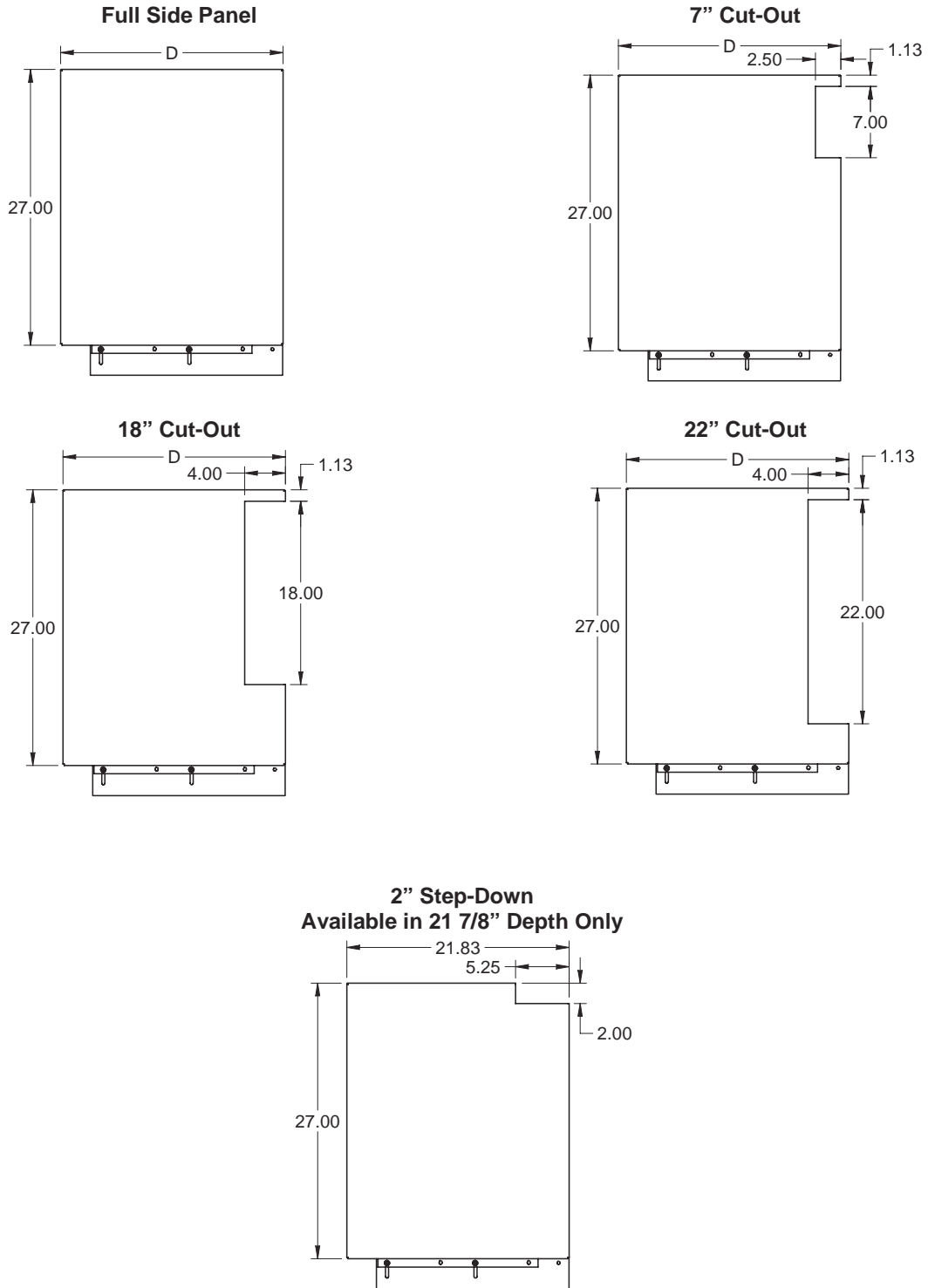

Utility Compartments and Filler Sections

Figure 24.1 – Utility Compartments

W = 12, 18 or 24 Inches

16 5/8" Utility Compartment

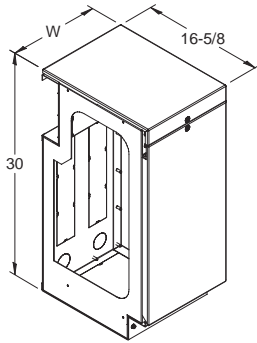

21 7/8" Utility Compartment

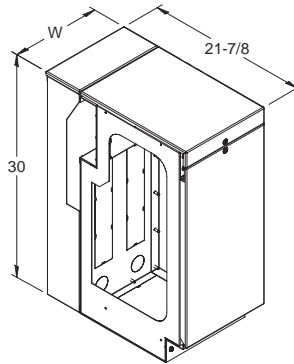

2" Step-Down Utility Compartment

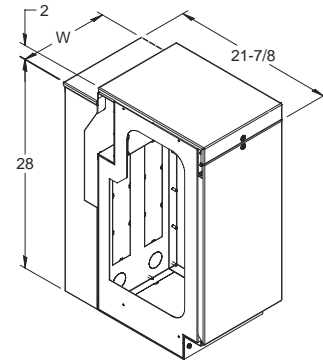
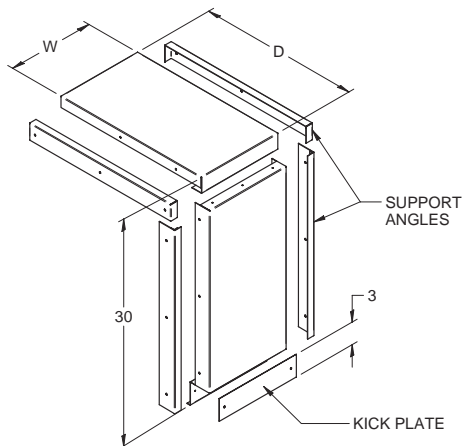

Figure 24.2 – Filler Sections

W = 6, 12 or 18 Inches

D = 16 5/8 or 21 7/8 Inches

Filler Section for Standard Height Units



Filler Section for Units with Sub-Base

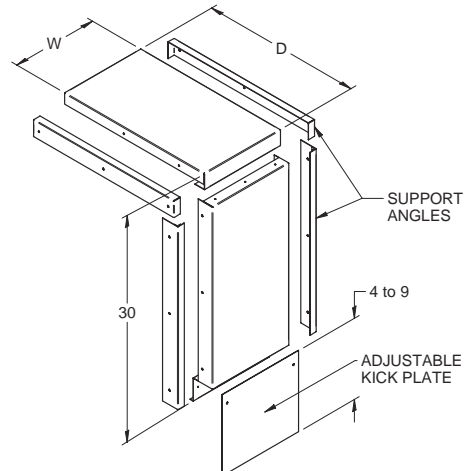

Sub-Bases and Duct Flanges

Figure 25.1 - Unit Sub-Base: Available in heights H = 1, 2, 4 or 6 inches

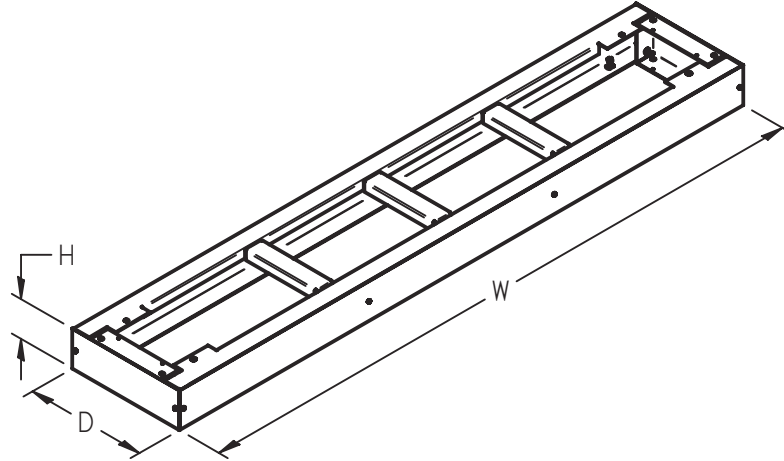

Table 25.1 – Sub-Base Dimensions

Dimensions (inches)	Model Size			
	750	1000	1250	1500
W	62	74	86	98
D (16 5/8" deep units)	13.65	13.65	13.65	13.65
D (21 7/8" deep units)	18.90	18.90	18.90	18.90

Figure 25.2 - Duct Flange

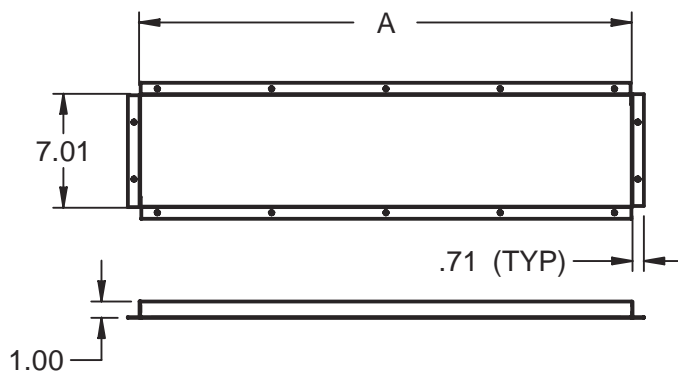

Table 25.2 – Duct Flange Dimensions

Dimensions (inches)	Model Size			
	750	1000	1250	1500
A	30.19	42.19	54.19	66.19

Wall Sleeves and Louvers

Figure 26.1 - Wall Sleeve

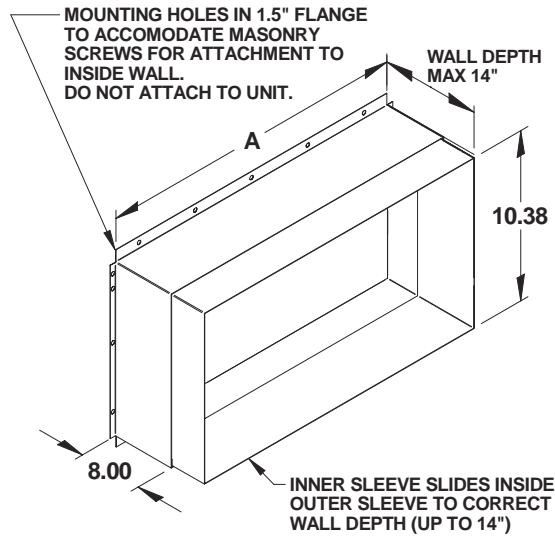

Figure 26.2 - Louver

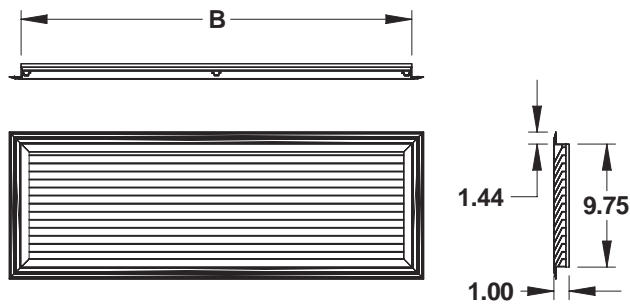

Table 26.1 – Wall Sleeve and Louver Dimensions

Dimensions (inches)	Model Size			
	750	1000	1250	1500
A	36	48	60	72
B	35.5	47.5	59.5	71.5

Piping Components

Modine offers the following piping components, shipped loose for field installation:

- Modulating Control Valve, 2-way or 3-way – for valve control units
- 2-Position Control Valve, 2-way or 3-way – for face & bypass units
- Balancing Valve
- Circuit Setter
- Drain with Hose Bib
- Shut Off Valves
- Strainer

Piping components are available in 1/2" and 3/4" sizes for chilled water units and 1/2" for hot water units. Piping components can be factory assembled and shipped with the unit for field installation. Factory assembled piping includes unions for quick connection to the coil. Units with both hot water and chilled water coils, and factory assembled piping, must have hot water and chilled water piping components mounted on opposite sides of the unit.

Figure 27.1 – Typical 2-Way Piping Diagram

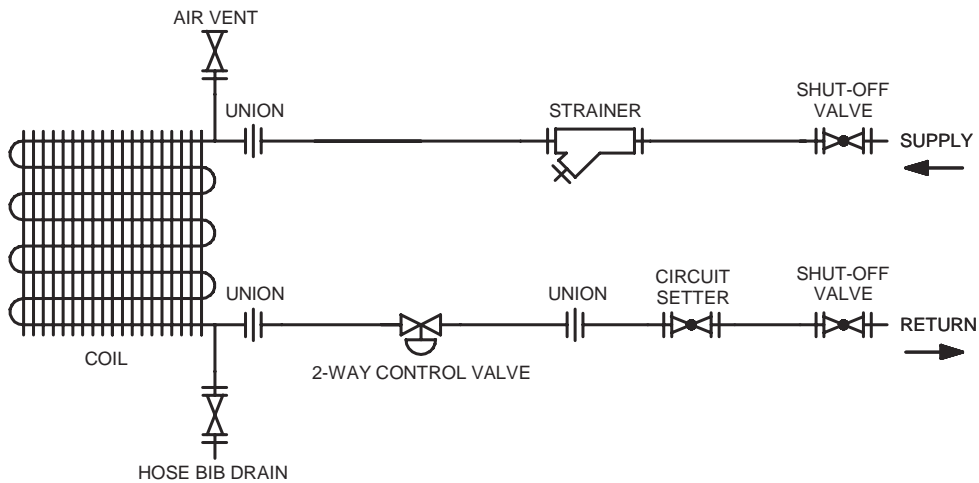
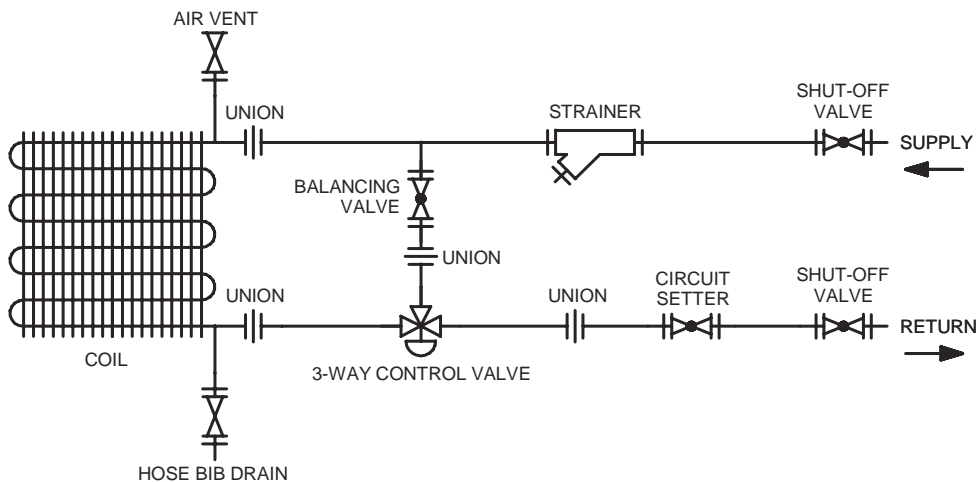

Figure 27.2 – Typical 3-Way Piping Diagram



INDOOR AIR SOLUTIONS

The Modine brand has been the industry standard since Arthur B. Modine invented and patented the first lightweight, suspended hydronic unit heater in 1923. No other manufacturer can provide the combined application flexibility, technical expertise and fast delivery found at Modine. Consult your local Modine distributor for help in solving your indoor air problems.

Products from Modine are designed to provide indoor air-comfort solutions for commercial, institutional and industrial applications. Whatever your heating, ventilating and cooling requirements, Modine has the product to satisfy your needs, including:

- Gas-fired unit heaters
- Gas-fired duct furnaces
- Gas-fired high-intensity infrared heaters
- Gas-fired low-intensity infrared heaters
- Steam/hot water unit heaters
- Steam/hot water cabinet unit heaters
- Steam/hot water commercial fin tube radiation
- Oil-fired unit heaters
- Electric unit heaters
- Indoor gravity and power vented single and multiple duct furnace make-up air units
- Indoor separated combustion single and multiple duct furnace make-up air units
- Outdoor single and multiple duct furnace make-up air units
- Direct-fired make-up air units
- R410 DX split system air conditioning and heat pump ceiling cassettes
- Ceiling cassettes, DX and chilled water
- Chilled water/hot water vertical unit ventilators

With burner capacities up to 7,862,000 Btu/hr and air-handling capacities as high as 60,000 CFM, Modine products are compatible with every fuel type, including:

- **Natural or Propane Gas • Steam/Hot Water • Oil • Electric**

Specific catalogs and computer-generated heat-loss calculations are available for each product. Catalogs 75-136 and 75-137 provide details on all Modine HVAC equipment.

Distributed By:



**Commercial Products Group
Modine Manufacturing Company**

1500 DeKoven Avenue
Racine, Wisconsin 53403-2552

Phone: 1.800.828.4328 (HEAT)
Fax: 1.800.204.6011

www.modine.com

© Modine Manufacturing Company 2010
Litho in USA