

***Ductless Split Ceiling Cassette  
Ductless Mini-Split Models SSD, SSH and SCW***



## Introduction

### INTRODUCTION

The Modine Cassette units effectively make each area served an independent controlled temperature zone. Through thermostatic control of operations, conditions can be varied to suit diverse requirements or activities. Optional fresh air intakes are available to provide for ventilation and recirculation of room air.

Modine Cassettes are available in a choice of three models – DX cooling and heat pumps in five model sizes and chilled water cooling in six model sizes – to properly match units to job requirements. Optional heating can be provided by factory installed electric heat or hot water modules, depending on model. This versatility eliminates compromising architecture or design. Important cost savings are often realized during building modernizations, as existing piping and/or wiring can frequently be reused.

Design techniques are incorporated in every Modine Cassette to reduce noise levels to an absolute minimum. These techniques include low blower speeds, rigid panel and cabinet construction, and sound-absorbent cabinet insulation.

For individual comfort, Modine Cassettes are available with electro-mechanical or micro-processor based controls. The micro-processor controller includes an infrared transmitter which enables room conditions to be maintained at a user defined set point. Modine Cassettes are also available with Carel microprocessor controls and network cards to allow units to be connected to a Building Management System.

<b>Table of Contents</b>	<b>Page</b>
<b>Model Identification</b> .....	3
<b>General Description</b>	
Standard Features.....	3
Options.....	4
Accessories.....	5
<b>Capacity Data</b>	
Air Conditioning and Heat Pump Units.....	6
Chilled Water Units.....	7
Optional Water Coil and Two Pipe Systems.....	8
<b>Dimensional Data</b>	
Small Chassis – SCW2/8, and SCW2/12.....	9
Medium Chassis – SCW 18 and SCW 20.....	10
Large Chassis – SCW 33 and SCW 36.....	11
Medium Chassis – SSD/SSH 18 and SSD/SSH 24.....	12
Large Chassis – SSD/SSH 30, SSD/SSH 36 and SSD/SSH 42.....	13
<b>Technical Data</b>	
Technical Data – Air Conditioning and Heat Pump Units .....	14
Technical Data – Chilled Water Units .....	15
Technical Data – Condensers for Air Conditioning Unit Systems.....	16
Technical Data – Condensers for Heat Pump Unit Systems.....	17
Electrical Data .....	18-19
Sound Data .....	19-20
<b>Condenser Information</b>	
Features – Air Conditioning System Condenser Units.....	21-22
Features – Heat Pump System Condenser Units.....	23

**Modine has a continuous product improvement program and therefore reserves the right to change design and specifications without notice.**

## General Description

### MODEL IDENTIFICATION

CEILING CASSETTE UNITS	
<b>SSD, SSH or SCW</b>	<b>Base Model:</b> SSD = Ceiling Cassette Unit – DX Cooling SSH = Ceiling Cassette Unit – Heat Pump SCW = Ceiling Cassette Unit – Chilled Water
<b>2/ or _ (blank)</b>	<b>Cabinet Size:</b> 2/ = Small Body (2 X 2 Series) _ = Medium Body (3 X 3 Series) or Large Body (3 X 4 Series)
<b>8 to 42</b>	<b>Model Size:</b> Nominal Cooling in Mbh (See Performance Data for Details)
<b>EM, MC or CA</b>	<b>Control Type:</b> EM = Electro-Mechanical Control MC = Microprocessor Controlled – Remote Control via Infrared or Pendant CA = Carel Controller
<b>Example:</b>	<b>SSD 18EM =</b> Ceiling Cassette Unit, DX Cooling, 18,000 Nominal BTU/Hr, Electro-Mechanical Control

### STANDARD FEATURES

<b>Construction</b>	Cases are manufactured from lightweight galvanized sheet steel with integral fan mounting rails for added strength. Fire resistant foam insulation (to UL94 VO) is fitted internally to provide both thermal and acoustic insulation.
<b>Evaporator</b>	All direct expansion units include a factory installed thermal expansion valve and utilize large surface area evaporator coils ideally positioned to optimize heat transfer and airflow. Each evaporator is manufactured from refrigeration quality copper tubes with mechanically bonded aluminum fins.
<b>Chilled Water Coil</b>	All chilled water units utilize large surface area coils positioned to optimize heat transfer and airflow. Each coil is manufactured from refrigeration quality copper tubes with mechanically bonded aluminum fins and are circuited from headers to ensure low water pressure drops.
<b>Fan</b>	All units, utilizing backward curved centrifugal fans, are statically and dynamically balanced for quiet operation. Fan impellers are made from either aluminum or fire retardant plastic (UL94 VO) for light weight and corrosion resistant operation. Fans are driven by an enclosed multi-speed external rotor motor allowing good heat dissipation and an increased motor efficiency. Fans come complete with thermal overload protection and sealed-for-life lubricated bearings.
<b>Filtration</b>	Wire framed filters are fitted. These are re-usable and may be vacuum cleaned.
<b>Condensate Pump</b>	A condensate pump and check valve are fitted to carry water out of the unit and stop water from flowing back into the condensate tray. The pump is fixed to a mounting bracket which can be withdrawn from the side of the chassis and incorporates an inspection hole to allow a visual check of the pump during operation. A float switch is fitted to stop the cooling action should the pump become blocked or fail.
<b>Air Vanes</b>	Air outlet vanes are designed to prevent condensation from forming. Vanes are manually adjustable on the 2 x 2 model units but driven by an electric motor on all other model units. Where fitted, the motorized air vanes can be set to auto sweep or can be stopped in a fixed position. Polystyrene blanking pieces are supplied with Cassette packing so that up to two fascia discharge slots can be blanked off.
<b>Alarm Status Relay</b>	The unit shall include a relay for unit failure notification. Normally open contact available for field connection.
<b>Start / Stop Terminals</b>	The unit shall include terminals for remote start/stop of the unit. The unit is enabled when contact between the terminals is closed. (only on Electro-Mechanical controls)

## General Description

### FACTORY INSTALLED OPTIONS

<b>Controls Option 1: Electro-Mechanical</b>	The unit shall include an electro-mechanical controller. The controller requires a 24V thermostat for on site wall mounting.
<b>Controls Option 2: Microprocessor</b>	<p>A custom designed microprocessor is fitted to the Modine Cassette to enable room conditions to be maintained at a user defined set point. Communication to the controller is by a hand held infrared transmitter or a wall mounted 'pendant' transmitter. Each type of transmitter includes a wall mounting bracket as standard.</p> <p><b>Note:</b> Units with Microprocessor controls <u>can not</u> be connected to a BMS. Select the Electro-Mechanical controls option, for field installed BMS interface, or the Carel controller version with optional Lonworks and BACnet network cards.</p> <p>The microprocessor allows five operating modes: fan only, dry cooling, cooling only, heating only, and heating/cooling with auto changeover for maximum versatility. A temperature set point between 58°F and 90°F can be selected.</p> <p>The microprocessor monitors indoor coil temperature and return air temperature. The receiver contains a self diagnostic feature. When a low indoor coil temperature is detected the cooling action is stopped. If a sensor fails then an alarm is displayed on the fascia mounted receiver. The microprocessor also limits the number of compressor starts per hour to reduce wear on the compressor.</p> <p>The infrared/pendant transmitter is used to switch the unit ON/OFF, change temperature settings, fan speed, operating mode, and to toggle the motorized air sweep (where fitted). The microprocessor also has a built-in clock which can be activated to enable the unit to be programmed with up to two separate operating periods on weekdays (Mon-Fri).</p> <p>The clock provides ON/OFF unit operation and is <i>not</i> a night set back or occupied/unoccupied control function. Mon-Fri will operate as a 'block' of days and cannot be programmed independently of one another. Saturdays and Sundays can each be programmed with up to two separate operating periods and are programmed independently of the weekdays and each other.</p> <p>A fascia mounted receiver displays ON/OFF, cool or heat, and timer/alarm status.</p>
<b>Controls Option 3: Carel Controller</b>	The unit shall be fitted with a programmable microprocessor controller designed to operate the unit according to pre-engineered control strategies. The Carel controller requires a wall sensor, wall stat or network interface card.
<b>LonWorks Card for Carel Controller</b>	The Carel microprocessor controller shall come equipped with a plug-in card allowing for complete compatibility with FT-10 LonWorks control system.
<b>BACnet Card for Carel Controller</b>	The Carel microprocessor controller shall come equipped with a plug-in card allowing for complete compatibility with an MS/TP BACnet control system.
<b>Time Clock Card for Carel Controller</b>	A time clock (card) shall be provided for "stand-alone" units where time functions, night and weekend setback, etc. are not transmitted from a building management system or remote central time clock. The time clock shall have a full 7 day schedule and calendar function incorporated. The 7 day schedule shall have two adjustable occupied/unoccupied periods per day. The calendar function shall allow 20 calendar periods (start date / stop date = 1 period).
<b>Electric Heat</b>	Electric heating elements will be factory fitted to the unit. Elements are manufactured for maximum surface area and lower working temperature for improved reliability. Thermal cut out protection switches are fitted to the electric heat circuit to protect against overheating.
<b>Hot Water Coil</b>	A hot water heating coil will be factory fitted (depending on unit size) in addition to the standard DX or chilled water coil to provide heating. The coil is manufactured from refrigeration quality copper tubes with mechanically bonded aluminum fins.
<b>Hot Water Coil Freeze Protection</b>	The unit shall be fitted with a freeze protection sensor to prevent freezing of the hot water coil assembly. When the sensor detects a freeze up condition it will force the flow control valve open and prevent the unit fan(s) from running.
<b>Disconnect Switch</b>	The unit shall be fitted with a power disconnect switch located on the control panel, sized for the full load amperage of the unit to enable the unit to be disconnected from the power supply prior to any maintenance.
<b>Step Up Transformer</b>	The unit shall be fitted with a 115V to 230V step up transformer for 115V supply power. Note: This option is not available for units with Electric Heat.
<b>Wall Mounted Pendant</b>	The unit shall include a wall mounted pendant for communication to the microprocessor controller. The pendant replaces the standard infrared remote control.

## FIELD INSTALLED ACCESSORIES

<b>Thermostats</b>	<p>Aquastat</p> <p>Mechanical thermostat: cooling only</p> <p>Mechanical thermostat with manual changeover: cooling + 1 stage of heat</p> <p>Digital thermostat with auto changeover: up to 2 stages of cooling and heating</p> <p>Digital programmable thermostat with auto changeover: up to 2 stages of cooling and heating</p>
<b>Carel Wall Sensor</b>	For units fitted with the Carel microprocessor controller, a temperature sensor and set point adjustment module with override button shall be mounted on the wall.
<b>Carel Wall Stat</b>	For units fitted with the Carel microprocessor controller, a digital thermostat shall be mounted on the wall.
<b>Display Module</b>	For units fitted with the Carel microprocessor controller, a hand-held display module shall be supplied for set point changes, control adjustments and unit troubleshooting. Note: at least one display module per facility is recommended.
<b>Spare Filters</b>	One set of replacement filters.
<b>Fresh Air Duct Collars</b>	The Cassette chassis features two or three fresh air knockouts depending on model size. Any number can be removed to allow fresh air to enter the unit. A duct collar is available for fastening to the unit to allow connection of a 3" flexible duct.
<b>Supply Air Duct Collars</b>	<p>A limited amount of conditioned air can be ducted from the unit by removing the branch duct knockouts (up to 2 per unit) and connecting flexible ducting. In the case of the 2 x 2 model units, there are a total of three knockouts positioned on three of the unit sides (one per side). In the case of the other model units, a total of four knockouts are available and are arranged in pairs along two of the unit sides (two per side). A duct collar is available to allow connection of a 5" or 6" (depending on units size) flexible duct to the Cassette.</p> <p>On the 2 x 2 range of units, it is recommended that only one of the three branch duct knockouts are utilized, due to the small capacity of the unit.</p>
<b>Shroud</b>	A sheet metal shroud is available to cover the unit housing when the unit is not mounted in a drop ceiling. Painted Sky White with hammertone finish.
<b>Two Position Spring Return Control Valves</b>	<p>For control of chilled water or hot water flow, a three-way, three-port diverting type valve or a two-way, two-port control valve is supplied loose for on site installation. Actuation is via a 24V signal from the unit's electrical panel.</p> <p>On a four pipe system where two-way valves are specified, the chilled water valve will be a normally closed type. The hot water valve will be a normally open type. Where three-way valves are specified, the same type valve will be supplied for both coils and should be installed normally closed to the coil in the case of the chilled water coil and normally open to the coil in the case of the hot water coil.</p> <p>On a two pipe changeover system where a two-way valve is specified, a normally closed valve is supplied. Where a three-way valve is specified, this should be installed normally closed to the coil. In both cases, a pipe mounted changeover thermostat is recommended to monitor water supply temperature and allow action of the valve accordingly.</p>
<b>Valve Packages: Two Position Spring Return Control Valve with Two Shut-Off Valves</b>	<p>For control of chilled water or hot water flow, a three-way, three-port diverting type valve piped with two shut-off valves and a bypass leg, or a two-way, two-port control valve piped with a shut-off valve and a second separate shut-off valve is supplied loose for on site installation. Actuation is via a 24V signal from the unit's electrical panel.</p> <p>On a four pipe system where two-way valves are specified, the chilled water valve will be a normally closed type. The hot water valve will be a normally open type. Where three-way valves are specified, the same type valve will be supplied for both coils and should be installed normally closed to the coil in the case of the chilled water coil and normally open to the coil in the case of the hot water coil.</p> <p>On a two pipe changeover system where a two-way valve is specified, a normally closed valve is supplied. Where a three-way valve is specified, this should be installed normally closed to the coil. In both cases, a pipe mounted changeover thermostat is recommended to monitor water supply temperature and allow action of the valve accordingly.</p>
<b>Low Ambient Kit</b>	Fan speed control for compressor operation down to 0°F outside temperature.

# CEILING CASSETTE



## Capacity Data: Air Conditioning and Heat Pump Units

Cooling Duty		Fan Speed						
		High		Medium		Low		
		TC BTU/h	SC BTU/h	TC BTU/h	SC BTU/h	TC BTU/h	SC BTU/h	
<b>SSD/SSH 18</b>	Air On: °F DB @ 50% RH	72	16500	14400	16300	13900	15800	13100
	75	17500	14900	17200	14400	16800	13500	
	80	19200	15600	18900	15100	18500	14200	
<b>SSD/SSH 24</b>	72	20000	16800	19600	16100	19300	15600	
	75	21000	17300	20600	16500	20400	16000	
	80	23000	18000	22600	17200	22200	16700	
<b>SSD/SSH 30</b>	72	27600	25000	27000	23600	26400	22200	
	75	29000	25800	27600	25000	27800	22800	
	80	31400	27000	31000	25400	30200	23800	
<b>SSD/SSH 36</b>	72	33400	28400	33000	27600	32200	26200	
	75	35000	29200	34600	28200	34000	26800	
	80	38200	30400	37800	29400	37000	27800	
<b>SSD/SSH 42</b>	72	37800	31600	37200	30200	36800	29400	
	75	39500	32400	39000	31000	38500	30000	
	80	42500	33400	42000	32000	41500	31000	

## Capacity Data: Heat Pump Units

Heating Capacity		Fan Speed			
		High TC BTU/h	Medium TC BTU/h	Low TC BTU/h	
<b>SSH 18</b>	Air on High °F DB/50% RH	50	19100	18900	18600
	60	17800	17600	17200	
	70	16400	16200	16000	
<b>SSH 24</b>	50	24400	24000	23800	
	60	22800	22600	22200	
	70	21400	21000	20800	
<b>SSH 30</b>	50	30400	30200	29800	
	60	29000	28800	28200	
	70	27400	27200	26800	
<b>SSH 36</b>	50	35800	35600	35000	
	60	34200	33800	33400	
	70	32400	32000	31600	
<b>SSH 42</b>	50	39500	39000	39000	
	60	38200	37800	37800	
	70	37200	36800	36600	

### Notes:

1. TC = Total Cooling Capacity
2. SC = Sensible Cooling Capacity
3. Cooling capacities are based on 95/75°F DB/WB Outdoor ambient.
4. Heating capacities are based on 47/43°F DB/WB Outdoor ambient.

# CEILING CASSETTE



## Performance Data: Air Conditioning Units

Cassette	Cooling BTU/h	SEER
SSD 18	21500	13
SSD 24	25400	13
SSD 30	34800	13
SSD 36	41800	13
SSD 42	45500	13

## Performance Data: Heat Pump Units

Cassette	Cooling BTU/h	Heating BTU/h	SEER	HSPF
SSH 18	21500	16400	13	7.7
SSH 24	25400	21400	13	7.7
SSH 30	34800	27400	13	7.7
SSH 36	41800	32400	13	7.7
SSH 42	45500	37000	13	7.7

### Notes:

Test conditions based on ARI210/240.

1. Cooling capacities are based on 80/67°F DB/WB Indoor and 82/65°F DB/WB Outdoor ambient.
2. Heating capacities are based on 70/60°F DB/WB Indoor and 47/43°F DB/WB Outdoor ambient.
3. All duties based on high fan speed except where stated otherwise.

## Capacity Data: Chilled Water Units

Cooling Duty	°F DB/ 50% RH	Chilled Water Inlet/Outlet °F							
		40/50°F				45/55°F			
		TC BTU/h	SC BTU/h	Flow gpm	Pr Drop PSI	TC BTU/h	SC BTU/h	Flow gpm	Pr Drop PSI
SCW2/8	72	5,236	5,156	1.1	2.4	3,999	3,999	0.8	1.5
	75	6,528	5,989	1.3	3.5	4,729	4,729	1.0	2.0
	80	10,037	7,529	2.0	7.6	7,026	6,107	1.4	4.0
SCW2/12	72	8,723	7,261	1.8	1.9	5,623	5,623	1.1	0.9
	75	10,831	8,173	2.2	2.7	7,502	6,604	1.5	1.4
	80	14,435	9,644	2.9	4.6	11,236	8,200	2.3	2.9
SCW 18	72	13,728	12,126	2.8	1.9	9,295	9,295	1.9	0.9
	75	17,478	13,840	3.5	2.8	11,447	10,853	2.3	1.4
	80	24,588	16,659	4.9	5.1	18,432	13,900	3.7	3.1
SCW 20	72	14,810	13,098	3.0	2.1	10,103	10,103	2.0	1.1
	75	18,956	14,985	3.8	3.3	12,341	11,716	2.5	1.5
	80	26,569	18,022	5.3	5.9	19,971	15,041	4.0	3.6
SCW 33	72	23,570	20,321	4.7	3.5	15,695	15,695	3.2	1.7
	75	29,100	22,928	5.8	5.1	19,912	18,365	4.0	2.7
	80	41,598	28,029	8.3	9.6	30,595	23,129	6.1	5.6
SCW 36	72	27,054	23,385	5.4	4.5	18,066	18,066	3.6	2.2
	75	33,895	26,690	6.8	6.7	22,721	21,074	4.6	3.3
	80	47,991	32,334	9.6	12.5	35,934	26,916	7.2	7.5

1. TC = Total Cooling Capacity
2. SC = Sensible Cooling Capacity
3. All duties based on high fan speed.
4. Pressure drops are coil only, excluding valves.

# CEILING CASSETTE



## Capacity Data: Chilled Water Units - Optional Hot Water Coil

Heating Capacity Air on High °F DB/50% RH		Hot Water 180°F Inlet / 160°F		
		Heating Capacity BTU/h	Flowrate GPM	Pressure Drop PSI
SCW2/8	50	16,819	1.8	3.9
	60	15,292	1.6	3.3
	70	13,799	1.4	2.7
SCW2/12	N/A	N/A	N/A	N/A
SCW 18	50	35,763	3.7	3.4
	60	32,480	3.4	2.9
	70	29,258	3.1	2.4
SCW 20	50	37,938	4.0	3.7
	60	34,401	3.6	3.2
	70	30,946	3.2	2.7
SCW 33	50	55,683	5.8	4.0
	60	51,120	5.3	3.5
	70	46,555	4.9	3.0
SCW 36	50	62,005	6.5	4.8
	60	56,762	5.9	4.1
	70	51,600	5.4	3.5

## Capacity Data: Air Conditioning and Heat Pump Units - Optional Hot Water Coil

Heating Capacity Air on High °F DB/50% RH		Hot Water 180°F Inlet / 160°F		
		Heating Capacity BTU/h	Flowrate GPM	Pressure Drop PSI
SSD/SSH 18	50	46,389	4.8	1.3
	60	42,598	4.4	1.1
	70	38,746	4.0	0.9
SSD/SSH 24	50	50,279	5.3	1.5
	60	46,153	4.8	1.2
	70	41,993	4.4	1.0
SSD/SSH 30	50	67,912	7.1	3.3
	60	62,277	6.5	2.8
	70	56,609	5.9	2.3
SSD/SSH 36	50	71,636	7.5	3.6
	60	65,640	6.9	3.1
	70	59,600	6.2	2.6
SSD/SSH 42	50	77,386	8.1	4.2
	60	70,803	7.4	3.5
	70	64,268	6.7	3.0

**Notes:**

1. All duties based on high fan speed.
2. Pressure drops are coil only, excluding valves.

# CEILING CASSETTE



## Capacity Data: Chilled Water Units - Two Pipe Changeover System

Heating Capacity	Air on High °F DB/50% RH	Hot Water 180°F Inlet / 160°F		
		Heating Capacity BTU/h	Flowrate GPM	Pressure Drop PSI
<b>SCW2/8</b>	50	28,389	3.0	11.0
	60	25,903	2.7	9.4
	70	23,605	2.5	8.0
<b>SCW2/12</b>	50	33,471	3.5	4.6
	60	30,715	3.2	4.0
	70	27,995	2.9	3.4
<b>SCW 18</b>	50	60,388	6.3	5.7
	60	55,127	5.8	4.8
	70	49,706	5.2	4.0
<b>SCW 20</b>	50	65,350	6.8	6.5
	60	59,887	6.3	5.6
	70	54,118	5.7	4.7
<b>SCW 33</b>	50	99,476	10.4	10.1
	60	91,494	9.6	8.8
	70	82,986	8.7	7.4
<b>SCW 36</b>	50	114,225	11.9	13.0
	60	105,132	11.0	11.2
	70	95,896	10.0	9.5

**Notes:**

3. All duties based on high fan speed.
4. Pressure drops are coil only, excluding valves.

# CEILING CASSETTE



## Dimensions – Small Chassis

## DUCTLESS SPLIT

SCW2/8 and SCW2/12

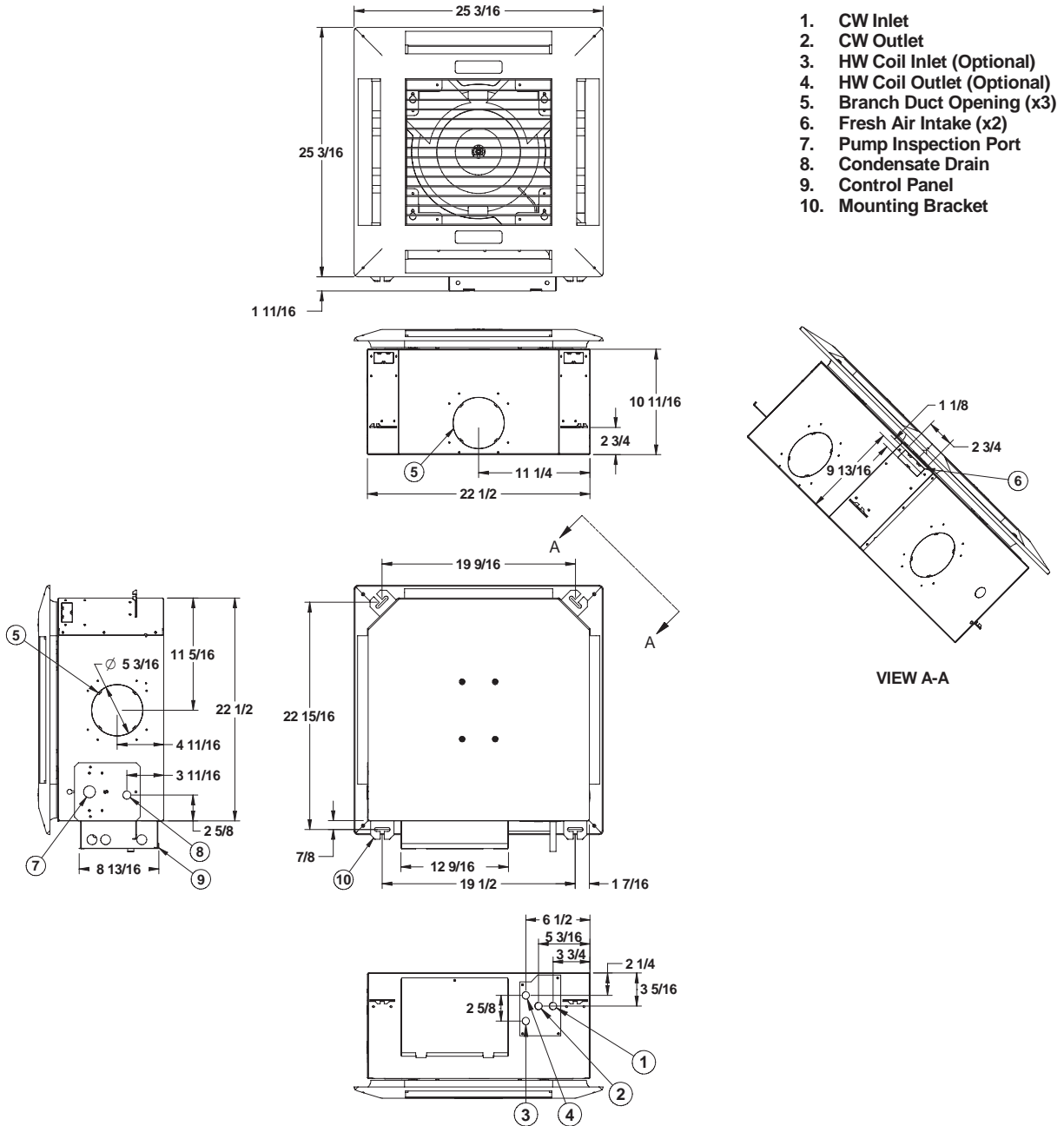

# CEILING CASSETTE



## Dimensions – Medium Chassis

## DUCTLESS SPLIT

SCW 18 and SCW 20

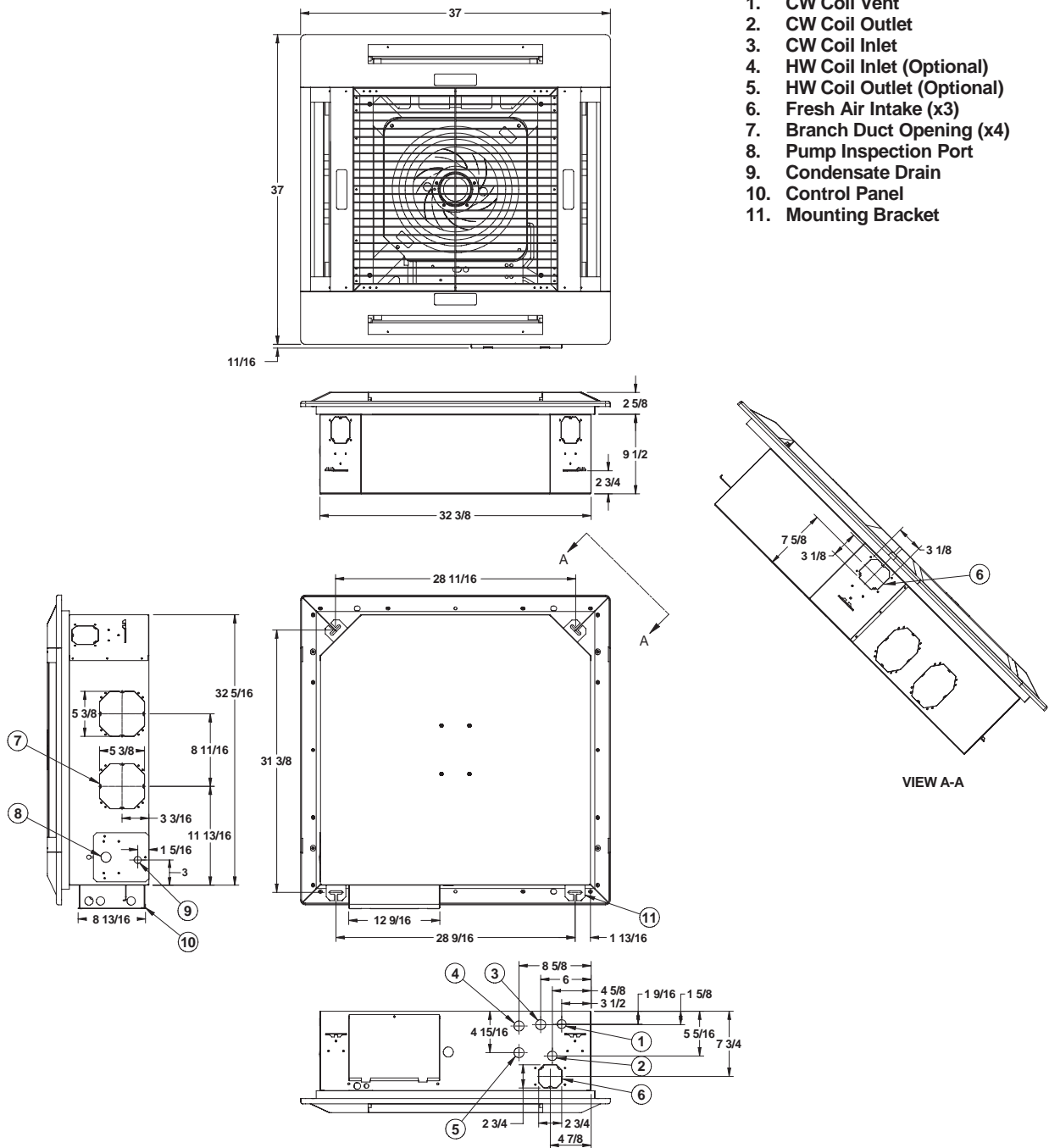

# CEILING CASSETTE



## DUCTLESS SPLIT

### Dimensions – Large Chassis

SCW 33 and SCW 36

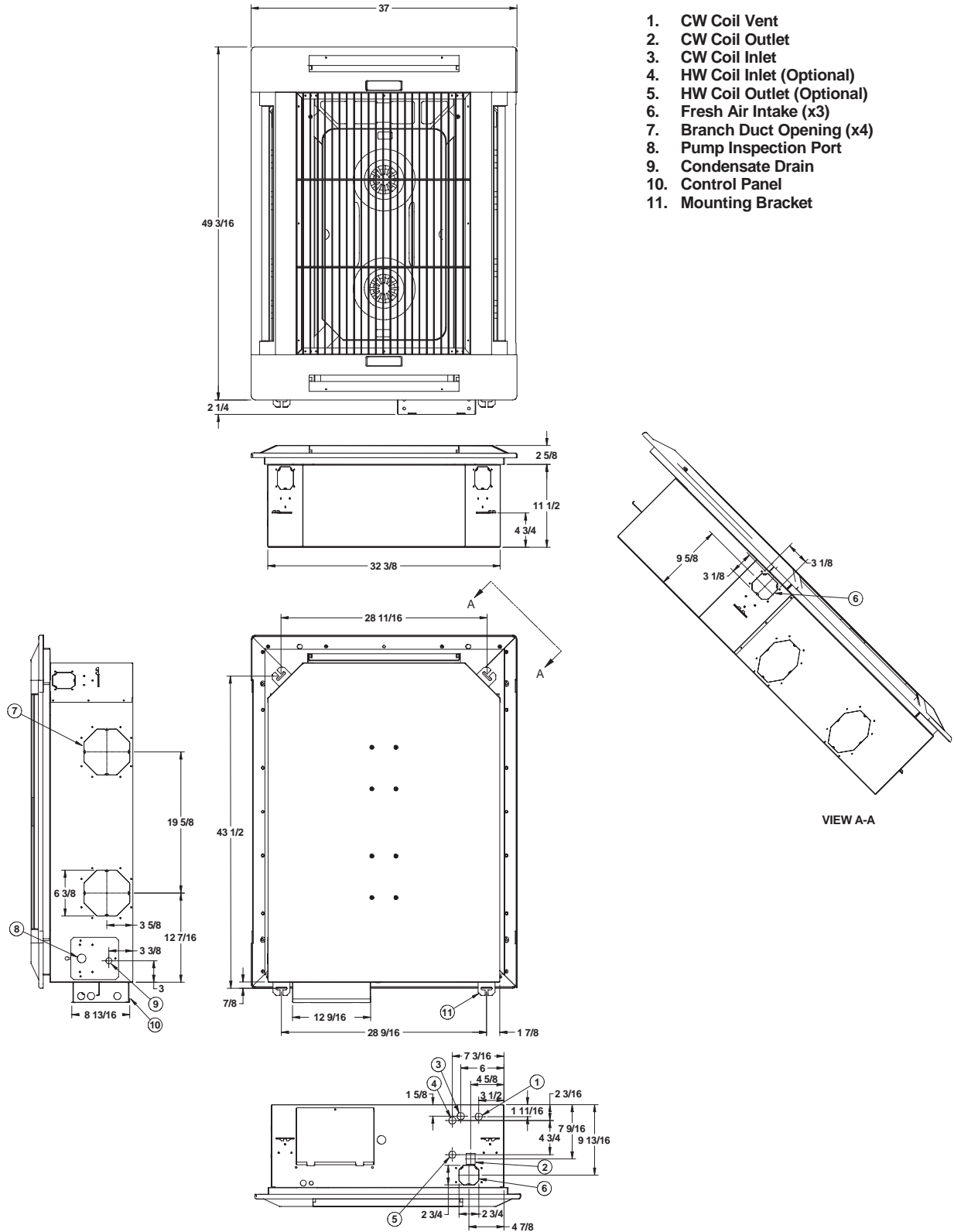

# CEILING CASSETTE



## Dimensions – Medium Chassis *DUCTLESS SPLIT*

SSD/SSH 18 and SSD/SSH 24

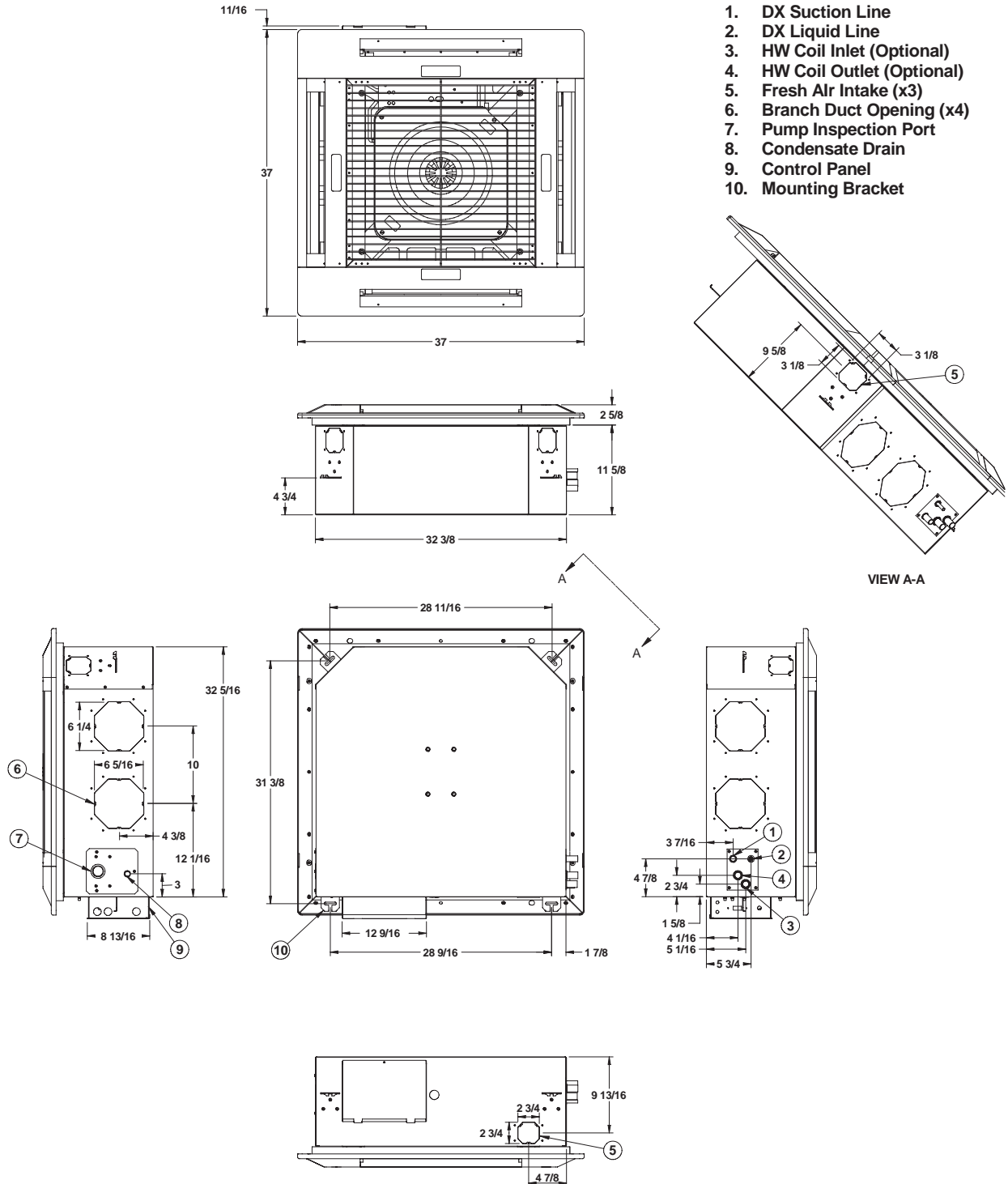

# CEILING CASSETTE



## Dimensions – Large Chassis *DUCTLESS SPLIT*

SSD/SSH 30, SSD/SSH 36 and SSD/SSH 42

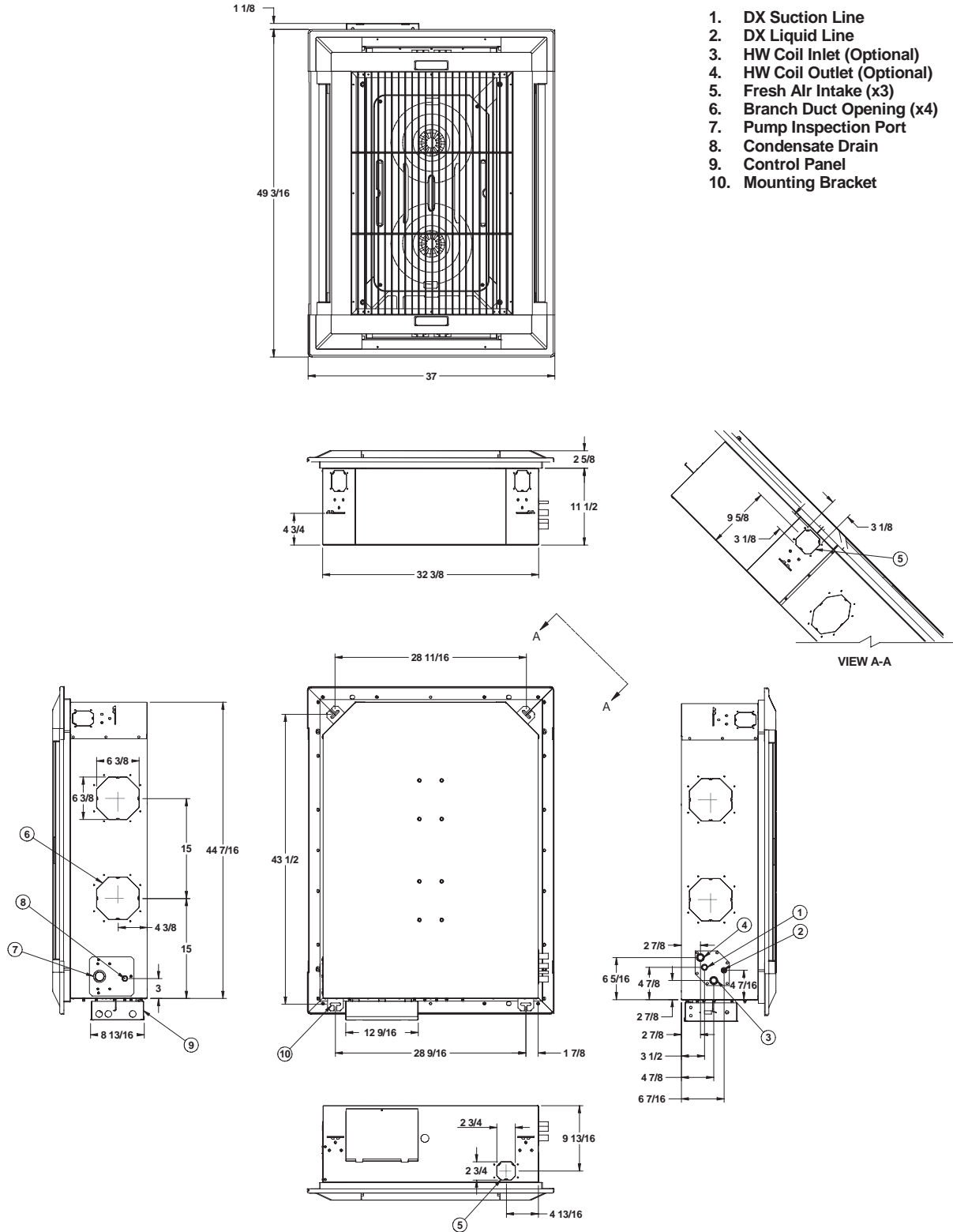

1. DX Suction Line
2. DX Liquid Line
3. HW Coil Inlet (Optional)
4. HW Coil Outlet (Optional)
5. Fresh Air Intake (x3)
6. Branch Duct Opening (x4)
7. Pump Inspection Port
8. Condensate Drain
9. Control Panel
10. Mounting Bracket

## Technical Data: Air Conditioning and Heat Pump Units

	Units	SSD/SSH 18	SSD/SSH 24	SSD/SSH 30	SSD/SSH 36	SSD/SSH 42	
Nominal Cooling Capacity (1)	BTU/h	19200	23000	31400	38200	42500	
Nominal Heating Capacity (2)	BTU/h	16400	21400	27400	32400	37200	
Nominal System SEER (3)		13	13	13	13	13	
HSPF		7.7	7.7	7.7	7.7	7.7	
<b>Construction</b>		High Impact Polystyrene Galvanized Steel Pearl Grey UL94 VO					
Material: Fascia							
Material: Chassis							
Color: Fascia							
Fire rating							
<b>Evaporator</b>		Finned Tube					
Type							
Quantity		1	1	1	1	1	
Face Area	Ft <sup>2</sup>	4.0	4.0	5.2	5.2	5.2	
Nominal Airflow	High	cfm	590	670	920	1000	1130
	Med	cfm	540	590	800	920	1000
	Low	cfm	465	540	680	800	920
Discharge		4-way	4-way	4-way	4-way	4-way	
<b>Fan</b>		Centrifugal					
Type							
Quantity		1	1	2	2	2	
Diameter	in	14	14	14	14	14	
Horsepower (per fan)	HP	1/8	1/8	1/8	1/8	1/8	
<b>Refrigeration</b>		1					
Number of Circuits							
Refrigerant Type		R-410A	R-410A	R-410A	R-410A	R-410A	
<b>Weights</b>		1					
Weight - Chassis	lb						
Weight - Fascia	lb	66	66	97	97	97	
		18	18	21	21	21	
<b>Connections (4)</b>		3/4					
Suction	in						
Liquid	in						
Condensate (ID)	in	3/8	3/8	3/8	3/8	3/8	
<b>Filtration</b>		Wire Framed Periframe					
Type							
Quantity		2	2	3	3	3	
Arrestance		80%	80%	80%	80%	80%	
<b>Condensate Pump</b>		30					
Maximum Head	in						
Nominal Flowrate	gpm	0.1	0.1	0.1	0.1	0.1	
<b>Options</b>		3.0					
Electric Heating Capacity	kW						
HW Heating Capacity (5)	BTU/h	38,746	41,993	56,609	59,600	64,268	
HW Coil Connection (OD)	in	7/8	7/8	7/8	7/8	7/8	
Branch Duct Connections	(qty)	1-4	1-4	1-4	1-4	1-4	
Branch Duct Diameter	in	5	5	6	6	6	
Ducted Air Volume (6)	cfm	115	130	180	200	220	
Fresh Air Connections	(qty)	1-3	1-3	1-3	1-3	1-3	
Fresh Air Duct Diameter	in	3	3	3	3	3	
Fresh Air Volume (7)	cfm	60	65	85	90	95	

- (1) Nominal cooling capacity based on 80/67°F DB/WB and 95/75°F DB/WB ambient
- (2) Nominal heating capacity based on 70/60°F DB/WB and 47/43°F DB/WB ambient.
- (3) Test conditions based on ARI 210/240.
- (4) Refrigerant line sizes should always match condensing unit connection sizes.
- (5) Nominal heating capacity based on 70/60°F DB/WB and water temperature of 180°F inlet / 160°F outlet.
- (6) Maximum air volume available through one branch duct 6' long, with Cassette fan(s) at high speed and corresponding fascia aperture closed.
- (7) Maximum fresh air through all knockouts connected to one 10' long duct with fan at high speed.

## Technical Data: Chilled Water Units

	Units	SCW2/8	SCW2/12	SCW 18	SCW 20	SCW 33	SCW 36
<b>Nominal Cooling Capacity (1)</b>	BTU/h	6,601	11,091	17,592	19,087	29,722	35,258
<b>Construction</b> Material: Fascia Material: Chassis Color: Fascia Fire rating		High Impact Polystyrene Galvanized Steel Pearl Grey UL94 VO					
<b>Chilled Water Coil</b> Type		Finned Tube					
Quantity		1	1	1	1	1	1
Face Area	Ft <sup>2</sup>	1.8	1.8	2.8	2.8	5.2	5.2
Nominal Airflow	High	350	350	630	700	970	1160
	Med	300	300	530	630	890	970
	Low	260	260	500	530	785	890
Discharge		4-way	4-way	4-way	4-way	4-way	4-way
Unit water Volume	gal	0.29	0.29	0.45	0.45	0.79	0.79
<b>Fan</b> Type		Centrifugal					
Quantity		1	1	1	1	2	2
Diameter	in	12	12	15	15	14	14
Horsepower (per fan)	HP	1/8	1/8	1/8	1/8	1/8	1/8
<b>Weights</b>							
Weight - Chassis	lb	40	40	64	64	97	97
Weight - Fascia	lb	5	5	18	18	21	21
<b>Connections</b>							
Chilled Water Inlet	in	5/8	5/8	7/8	7/8	7/8	7/8
Chilled Water Outlet	in	5/8	5/8	7/8	7/8	7/8	7/8
Condensate (ID)	in	3/8	3/8	3/8	3/8	3/8	3/8
<b>Filtration</b> Type		Wire Framed Periframe					
Quantity		1	1	2	2	3	3
Arrestance		80%	80%	80%	80%	80%	80%
<b>Condensate Pump</b>							
Maximum Head	in	30	30	30	30	30	30
Nominal Flowrate	gpm	0.1	0.1	0.1	0.1	0.1	0.1
<b>Options</b>							
Electric Heating Capacity	kW	1.5	1.5	3.0	3.0	5.0	5.0
HW Heating Capacity (2)	BTU/h	13,799	N/A	29,258	30,946	46,455	51,600
HW Coil Connection (OD)	in	5/8	N/A	5/8	5/8	5/8	5/8
Branch Duct Connections	(qty)	1-3	1-3	1-4	1-4	1-4	1-4
Branch Duct Diameter	in	5	5	5	5	6	6
Ducted Air Volume (3)	cfm	80	80	100	125	200	220
Fresh Air Connections	(qty)	1-2	1-2	1-3	1-3	1-3	1-3
Fresh Air Duct Diameter	in	3	3	3	3	3	3
Fresh Air Volume (4)	cfm	40	40	60	65	90	95

(1) Nominal cooling capacity based on 80/67°F DB/WB and water temperature of 45°F inlet / 55°F outlet.

(2) Nominal heating capacity based on 70/60°F DB/WB and water temperature of 180°F inlet / 160°F outlet.

(3) Maximum air volume available through one branch duct 6' long, with Cassette fan(s) at high speed and corresponding fascia aperture closed.

(4) Maximum fresh air through all knockouts connected to one 10' long duct with fan at high speed.

# CEILING CASSETTE



## Technical Data: Condensers for Air Conditioning Units

Cassette Unit		SSD 18	SSD 24	SSD 30	SSD 36	SSD 42
Condenser Model		YCJD18	YCJD24	YCJD30	YCJD36	YCJD42
	Units					
Nominal System Cooling Capacity	BTU/h	18,000	24,000	30,000	36,000	42,000
Nominal System SEER		13	13	13	13	13
<b>Construction</b> Material: Chassis Color		Pre-Treated Galvanized Painted Steel Champagne				
<b>Dimensions/Weights</b> Height (includes Fan Guard)	in	28	28	28	28	30
Width	in	23½	23½	23½	29	29
Depth	in	23½	23½	23½	29	29
Weight	lb	97	129	131	145	173
<b>Compressor</b> Type Crankcase Heater Fitted		Rotary No	Recip No	Recip No	Recip No	Recip No
<b>Condenser</b> Coil Construction		Plate Fin Microchannel	Plate Fin Microchannel	Plate Fin Microchannel	Plate Fin Microchannel	Plate Fin Microchannel
<b>Connections (1)</b> Suction	in	5/8	3/4	3/4	3/4	7/8
Liquid	in	3/8	3/8	3/8	3/8	3/8
<b>Refrigerant Charge</b> Condenser-factory charge	lbs-oz	3 - 3	3 - 13	3 - 14	4 - 9	4 - 5
Charge Required-Per Foot of Pipework	oz	0.58	0.62	0.62	0.62	0.67

(1) Refrigerant line sizes should always match condensing unit connection sizes.

## Technical Data: Condensers for Heat Pump Units

Cassette Unit		SSH 18	SSH 24	SSH 30	SSH 36	SSH 42
Condenser Model		YHJD18	YHJD24	YHJD30	YHJD36	YHJD42
	Units					
Nominal System Cooling Capacity	BTU/h	18,000	24,000	30,000	36,000	42,000
Nominal System SEER		13	13	13	13	13
<b>Construction</b> Material: Chassis Color		Pre-Treated Galvanized Painted Steel Champagne				
<b>Dimensions/Weights</b> Height (includes Fan Guard)	in	28	32	36	40	40
Width	in	34	34	34	34	34
Depth	in	34	34	34	34	34
Weight	lb	172	184	196	208	208
<b>Compressor</b> Type Crankcase Heater Fitted		Scroll No	Recip Yes	Recip Yes	Recip Yes	Scroll No
<b>Condenser</b> Coil Construction		Round Tube Plate Fin	Round Tube Plate Fin	Round Tube Plate Fin	Round Tube Plate Fin	Round Tube Plate Fin
<b>Connections (1)</b> Suction	in	3/4	3/4	3/4	3/4	7/8
Liquid	in	3/8	3/8	3/8	3/8	3/8
<b>Refrigerant Charge</b> Condenser-factory charge	lbs-oz	6 - 6	8 - 13	9 - 0	9 - 7	9 - 12
Charge Required-Per Foot of Pipework	oz	0.62	0.62	0.62	0.62	0.67

(1) Refrigerant line sizes should always match condensing unit connection sizes.

## Electrical Data: DX and Chilled Water Units

Model Sizes:	Units	2/8 & 2/12	18, 20 & 24	30, 33, 36, & 42
<b>Standard Unit Data</b>	Chassis Size	Small (2 x 2)	Medium (3 x 3)	Large (3 x 4)
Power Supply		208-230V / 1 Ph / 60Hz	208-230V / 1 Ph / 60Hz	208-230V / 1 Ph / 60Hz
Full Load Amps	A	0.65	0.85	1.3
Minimum Circuit Amps (MCA)	A	0.74	0.99	1.4
Recommended Fuse	A	10	10	10
<b>With Optional Electric Heat <sup>1</sup></b>		208-230V / 1 Ph / 60Hz	208-230V / 1 Ph / 60Hz	208-230V / 1 Ph / 60Hz
Power Supply		208-230V / 1 Ph / 60Hz	208-230V / 1 Ph / 60Hz	208-230V / 1 Ph / 60Hz
Electric Heat Capacity	kW	1.5	3.0	5.0
Full Load Amps	A	7.2	13.9	23.1
Minimum Circuit Amps (MCA)	A	8.9	19.3	28.8
Recommended Fuse with Heat	A	15	20	30
<b>With Optional Booster Xfmr <sup>2</sup></b>		115V / 1 Ph / 60Hz	115V / 1 Ph / 60Hz	115V / 1 Ph / 60Hz
Power Supply		115V / 1 Ph / 60Hz	115V / 1 Ph / 60Hz	115V / 1 Ph / 60Hz
Full Load Amps	A	1.3	1.7	2.5
Minimum Circuit Amps (MCA)	A	1.5	2.0	2.8
Recommended Fuse	A	10	10	10

**Notes:**

1 Standard Unit fitted with optional electric heating elements. Available with 230V model units only.

2 Standard unit fitted with optional booster transformer for connection to a 115V electrical supply. Electric heat not available in conjunction with this option.

## Electrical Data: Condensers for Air Conditioning Units

Cassette Unit		SSD 18	SSD 24	SSD 30	SSD 36	SSD 42
Condenser Model		YCJD18	YCJD24	YCJD30	YCJD36	YCJD42
	Units					
<b>Standard Unit Data</b>		208-230V	208-230V	208-230V	208-230V	208-230V
Power Supply		1 Ph / 60Hz	1 Ph / 60Hz	1 Ph / 60Hz	1 Ph / 60Hz	1 Ph / 60Hz
MCA	A	9.8	12.4	14.7	17.9	21.5
Maximum Overcurrent Device Amps ①	A	15	20	25	30	35
Minimum Overcurrent Device Amps ②	A	15	15	15	20	25
<b>Compressor</b>						
Rated Load Amps (RLA)	A	7.4	9.3	10.6	13.1	16.0
Locked Rotor Amps (LRA)	A	40	43	54	74	84
<b>Condenser Fan</b>						
Rated Load Amps (RLA)	A	0.5	0.8	1.4	1.5	1.5
Rated Horsepower	hp	1/12	1/8	1/4	1/4	1/4

① Dual element fuses or HACR circuit breaker. Maximum allowable overcurrent protection.

② Dual element fuses or HACR circuit breaker. Minimum recommended overcurrent protection.

**Electrical Data: Condensers for Heat Pump Units**

Cassette Unit		SSH 18	SSH 24	SSH 30	SSH 36	SSH 42
Condenser Model		YHJD18	YHJD24	YHJD30	YHJD36	YHJD42
	Units					
<b>Standard Unit Data</b>						
Power Supply		208-230V 1 Ph / 60Hz	208-230V 1 Ph / 60Hz	208-230V 1 Ph / 60Hz	208-230V 1 Ph / 60Hz	208-230V 1 Ph / 60Hz
MCA Maximum Overcurrent Device Amps ①	A	11.9	11.2	14.1	19.7	28.6
Minimum Overcurrent Device Amps ②	A	20	15	20	30	50
	A	15	15	15	20	30
<b>Compressor</b>						
Rated Load Amps (RLA)	A	9.0	8.3	10.6	14.7	21.8
Locked Rotor Amps (LRA)	A	48	43	54	74	105
<b>Condenser Fan</b>						
Rated Load Amps (RLA)	A	0.7	0.8	0.8	1.5	1.5
Rated Horsepower	hp	1/10	1/8	1/8	1/4	1/4

① Dual element fuses or HACR circuit breaker. Maximum allowable overcurrent protection.

② Dual element fuses or HACR circuit breaker. Minimum recommended overcurrent protection.

**Sound Data: DX and Chilled Water Units**

MERCER TABLE	Frequency Hz		SPL (1)	Sound Pressure Frequency Spectrum, dB (1)						
	Models	Fan Speed	dBA	125 Hz	250 Hz	500 Hz	1000 Hz	2000 Hz	4000 Hz	8000 Hz
SCW2/8		High	29	37	37	33	29	21	14	10
		Med	26	34	34	30	24	15	12	10
		Low	22	31	29	25	17	8	10	8
SCW2/12		High	35	42	41	38	35	28	21	12
		Med	32	38	39	36	32	24	16	10
		Low	29	37	37	33	29	21	14	10
SSD/SSH 18 SCW 18		High	43	41	45	38	40	33	25	17
		Med	39	39	41	35	36	27	19	16
		Low	38	38	40	34	34	25	18	16
SSD/SSH 24 SCW 20		High	46	43	47	40	43	37	29	19
		Med	43	41	45	38	40	33	25	17
		Low	39	39	41	35	36	27	19	16
SSD/SSH 30 SCW 33		High	48	51	49	46	42	34	22	19
		Med	44	50	46	43	38	28	18	17
		Low	42	49	44	41	36	25	17	16
SSD/SSH 36 SSD/SSH 42 SCW 36		High	52	54	54	50	46	41	27	24
		Med	48	51	49	46	42	34	22	19
		Low	45	50	47	44	39	31	19	18

**Note: (1)** - SPL is the overall Sound Pressure Level measured at a distance of 5 ft below the fascia in free field, dry coil conditions, referenced to  $2 \times 10^{-5}$  Pa

## Sound Data: Condensers for Air Conditioning and Heat Pump Units

Model		Cooling	Heating
YCJD18	dBA	75	
YCJD24	dBA	76	
YCJD30	dBA	76	
YCJD36	dBA	76	
YCJD42	dBA	76	
YHJD18	dBA	70.1	70.9
YHJD24	dBA	75.8	75.0
YHJD30	dBA	74.7	74.8
YHJD36	dBA	76.5	76.5
YHJD42	dBA	72.0	76.0

Rated in accordance with ARI 270-95 standards.

## Features

### Air Conditioning System Condensing Units

#### Up Flow Condenser, Model: YCJD18S41S1H through YCJD42S41S1H

##### Standard Features

- Quality Condenser Coils** – The coil is constructed of aluminum microchannel tubing and enhanced aluminum fins for increased efficiency and corrosion protection.
- Protected Compressor** – The compressor is internally protected against high pressure, temperature, and externally by a factory installed high pressure switch. This is accomplished by simultaneous operation of high pressure relief valve and a temperature sensor which protects the compressor if undesirable operating conditions occur. A liquid line filter-drier further protects the compressor.
- Hard Start Kit** - Provides increased starting torque for areas with low voltage.
- Durable Finish** – The cabinet is made of pre-painted steel. The pre-treated galvanized steel provides a better paint to steel bond, which resists corrosion and rust creep. Special primer formulas and matted-textured finish ensure less fading when exposed to sunlight.
- Lower Installed Cost** – Installation time and costs are reduced by easy power and control wiring connections. Available in sweat connect models only. The unit contains enough refrigerant for matching indoor coils and 15 feet of interconnecting piping. The small base dimension means less space is required on the ground or roof.
- Top Discharge** – The warm air from the top mounted fan is blown up and away from the structure and any landscaping. This allows compact location on multi-unit applications.
- Low Operating Sound Level** – The upward air flow carries the normal operating noise away from the living area. The rigid top panel effectively isolates any motor sound. Isolator mounted compressor and rippled fins of the condenser coil muffle the normal fan motor and compressor operating sounds.
- Low Maintenance** – Long life permanently lubricated motor-bearings need no annual servicing.
- Easy Service Access** – Fully exposed refrigerant connections and a single panel covering the electrical controls makes for easy servicing of the unit.
- Secured Service Valves** – Secured re-usable service valves are provided on both the liquid and vapor sweat connections for ease of evacuating and charging.
- U.L. and C.U.L. Listed** – Approved for outdoor application.

##### Field Installed Accessories

- Low Ambient Kit – Fan Cycle Kit** for operation down to 0°F outside temperature. Certified in accordance with the Unitary Small Equipment certification program, which is based on ARI Standard 210/240.

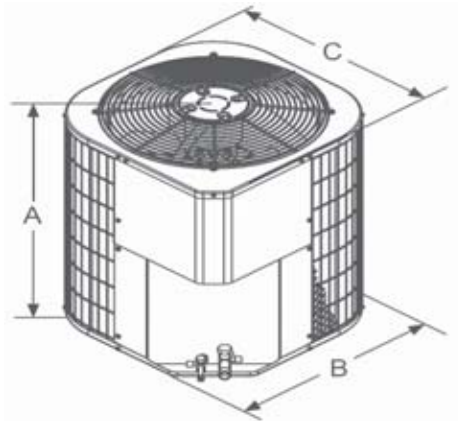

	YCJD18	YCJD24	YCJD30	YCJD36	YCJD42
A = Height	28	28	28	28	30
B = Depth	23½	23½	23½	29	29
C = Width	23½	23½	23½	29	29

## Features

### Heat Pump System Condenser Units

#### Up Flow Condenser, Model: YHJD18S41S1 through YHJD42S41S1

##### Standard Features

- Quality Condenser Coils** – The coil is constructed of copper tubing and enhanced aluminum fins for increased efficiency and corrosion protection.
- Protected Compressor** – The compressor is internally protected against high pressure, temperature, and externally by a factory installed high pressure switch. This is accomplished by simultaneous operation of high pressure relief valve and a temperature sensor which protects the compressor if undesirable operating conditions occur. A liquid line filter-drier further protects the compressor.
- Hard Start Kit** – (On model sizes 24, 30 and 36) Provides increased starting torque for areas with low voltage.
- Durable Finish** – The cabinet is made of pre-painted steel. The pre-treated galvanized steel provides a better paint to steel bond, which resists corrosion and rust creep. Special primer formulas and matted-textured finish ensure less fading when exposed to sunlight.
- Lower Installed Cost** – Installation time and costs are reduced by easy power and control wiring connections. Available in sweat connect models only. The unit contains enough refrigerant for matching indoor coils and 15 feet of interconnecting piping. The small base dimension means less space is required on the ground or roof.
- Top Discharge** – The warm air from the top mounted fan is blown up and away from the structure and any landscaping. This allows compact location on multi-unit applications.
- Low Operating Sound Level** – The upward air flow carries the normal operating noise away from the living area. The rigid top panel effectively isolates any motor sound. Isolator mounted compressor and rippled fins of the condenser coil muffle the normal fan motor and compressor operating sounds.
- Low Maintenance** – Long life permanently lubricated motor-bearings need no annual servicing.
- Easy Service Access** – Fully exposed refrigerant connections and a single panel covering the electrical controls makes for easy servicing of the unit.
- Secured Service Valves** – Secured re-usable service valves are provided on both the liquid and vapor sweat connections for ease of evacuating and charging.
- U.L. and C.U.L. Listed** – Approved for outdoor application.

Certified in accordance with the Unitary Small Equipment certification program, which is based on ARI Standard 210/240.

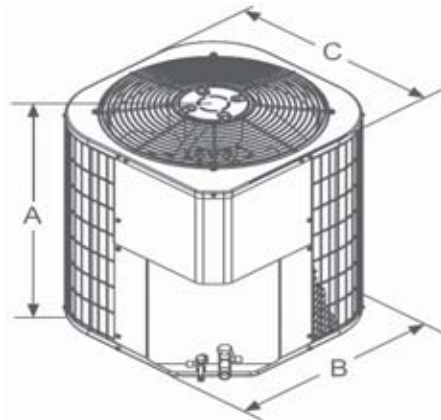

	YHJD18	YHJD24	YHJD30	YHJD36	YHJD42
A = Height	28	32	36	40	40
B = Depth	34	34	34	34	34
C = Width	34	34	34	34	34

## INDOOR AIR SOLUTIONS

The Modine brand has been the industry standard since Arthur B. Modine invented and patented the first lightweight, suspended hydronic unit heater in 1923. No other manufacturer can provide the combined application flexibility, technical expertise and fast delivery found at Modine. Consult your local Modine distributor for help in solving your indoor air problems.

Products from Modine are designed to provide indoor air-comfort solutions for commercial, institutional and industrial applications. Whatever your heating, ventilating and cooling requirements, Modine has the product to satisfy your needs, including:

- Gas-fired unit heaters
- Gas-fired duct furnaces
- Gas-fired high-intensity infrared heaters
- Gas-fired low-intensity infrared heaters
- Steam/hot water unit heaters
- Steam/hot water cabinet unit heaters
- Steam/hot water commercial fin tube radiation
- Oil-fired unit heaters
- Electric unit heaters
- Indoor gravity vented single and multiple duct furnace make-up air units
- Indoor separated combustion single and multiple duct furnace make-up air units
- Outdoor single and multiple duct furnace make-up air units
- Direct-fired make-up air units
- R410 DX split system air conditioning and heat pump ceiling cassettes
- Chilled water/hot water ceiling cassettes
- Chilled water/hot water vertical unit ventilators

With burner capacities up to 7,862,000 Btu/hr and air-handling capacities as high as 60,000 CFM, Modine products are compatible with every fuel type, including:

- **Natural or Propane Gas • Steam/Hot Water • Oil • Electric**

Specific catalogs and computer-generated heat-loss calculations are available for each product. Catalogs 75-136 and 75-137 provide details on all Modine HVAC equipment.

Distributed By:



**Commercial Products Group  
Modine Manufacturing Company**

1500 DeKoven Avenue  
Racine, Wisconsin 53403-2552

Phone: 1.800.828.4328 (HEAT)  
Fax: 1.800.204.6011

[www.modine.com](http://www.modine.com)

© Modine Manufacturing Company 2010  
Litho in USA